



# POSlglaze Side Fix

## **INSTALLATION GUIDE**

### **Safety**

Gloves for handling Glass  
Eye protection goggles  
Ear protection

### **Tools**

Drill & suitable drill bits  
Spirit level  
Tape measure  
Hole blower (concrete fixings)  
Hammer  
Socket set 1/2inch  
Torque wrench 1/2  
Blocks to support glass  
Quick grip  
Posi Spanner  
Glass cleaner and rag

**Should any problems arise or you have any questions please don't  
hesitate to contact us:**

**T: +44 (0)1208 261 040**

**F: +44 (0)1208 261 041**

**E:- [sales@pure-vista.com](mailto:sales@pure-vista.com)**

**[www.pure-vista.co](http://www.pure-vista.co)**



# POSlglaze Side Fix

## INSTALLATION GUIDE

1.

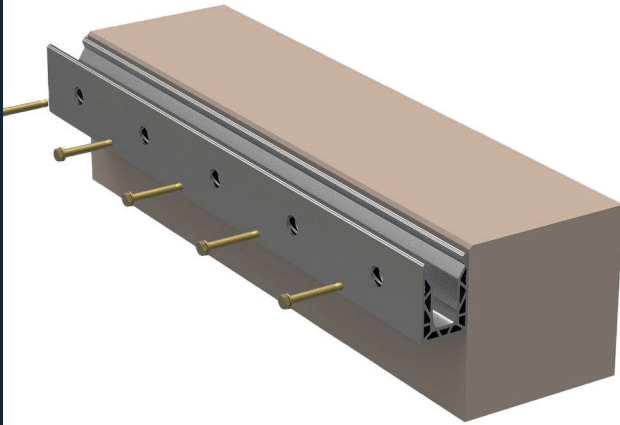

### FIT THE CHANNEL

The POSlglaze side channel should be placed onto its designated position and the holes marked onto the substrate for drilling. Remove the channel before drilling. Once the shoe is lined up with the holes and is level, the fixings should be tightened in accordance with the bolt manufacturer's instructions. M12 bolts/fixings must be used. The dowels should be used to align the channels and an inhibitor or clear sealant (Neutral Cure/low-modulus silicone) rubbed on the raw aluminium when the channels are butted together. This should be wiped clear on the channel surface.

Ensure the channel is clean inside before fitting the glass. If cutting the channel make sure all metal filings (swarf) are removed. \*

2.

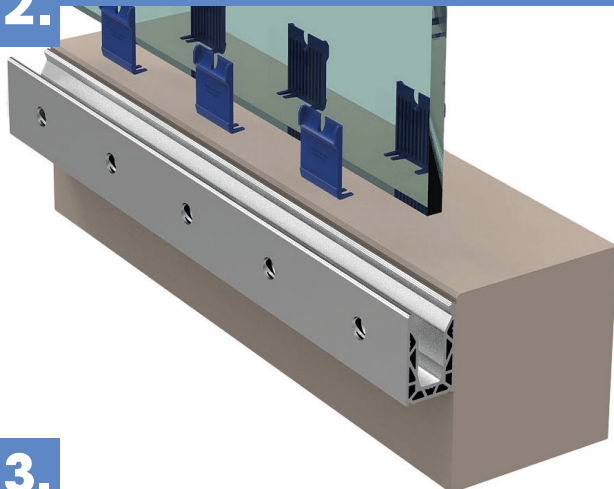

### CLAMP THE GLASS

Make the clamps by slotting the left and right sides together. Clamp these to the bottom edge of the glass at 250mm intervals, starting from 125mm from the first edge (if using 4 clamps per metre). Squeeze the clamps tight around the glass and position the panel into the balustrade channel. When using 3 clamps per metre (12 + 13.5mm glass) the spacing needs to be 200mm from the end and then 300mm centres. The glass can now be lowered into the channel. You must ensure 3 or 4 clamps are used per metre.

3.

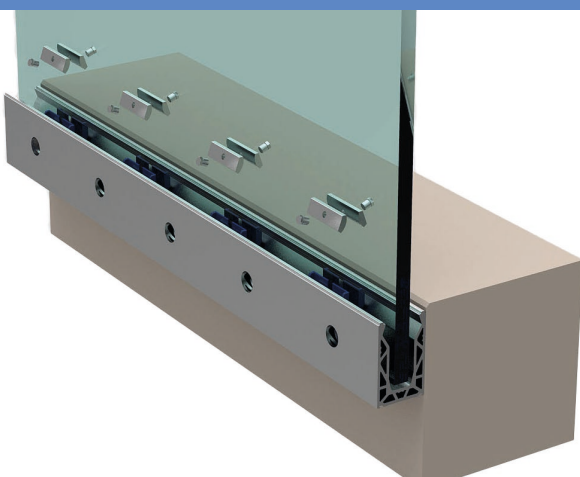

### FIT THE BOLTS

Once the glass is in position, loosely screw the bolts into the clamp bars. The screw needs to go into the flat side, the curved side will fit into the clamp. Slide the aluminium bars curved side down into the recess at the top of each clamp, on both sides of the glass. Loosely screw the bolts into the bars.

\* When fitting to metalwork a barrier between different metal types must be used. Additional waterproofing may be required. We strongly advise measuring and ordering the glass after installation of the channel. Gaps between the glass should be no less than 5mm.

In extreme temperature changes the profiles may expand and contract. Small gaps may need to be left between profiles.



4.

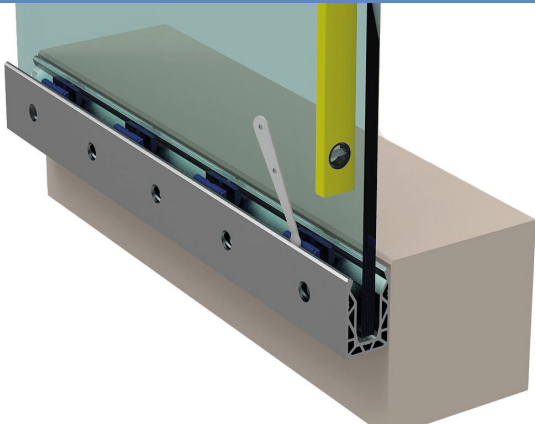

### ADJUST THE GLASS

With the bolts loosely in place, the glass panel will be able to move a few millimetres in each direction. Align the panel as required by tightening the bolts using the angled spanner. Both sides need to be tightened to make sure the glass is fixed into place. Give the bolts an additional half turn from their tight position to ensure that the glass is securely held in place. A torque of 8Nm should be applied. An adhesive, such as Loctite, should be used on the threads once the glass is set.

5.

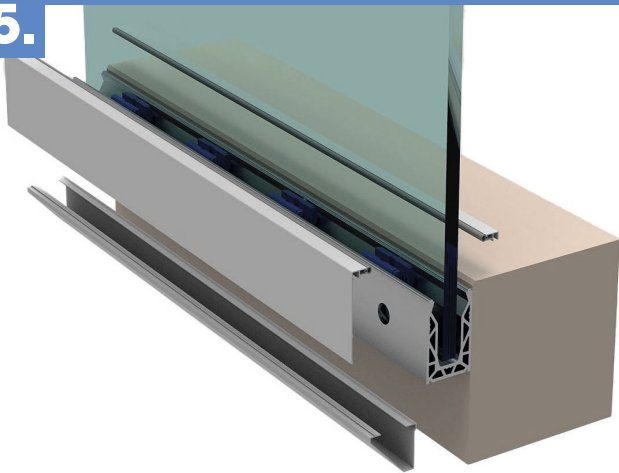

### ADD THE TOP BEAD

Top bead and gasket simply slip or clip onto the top edge of the balustrade channel for a tidy finish. Use a soft mallet to push this in if required.

If you're using an end-cap you can position this now. There are 2 versions of end caps. A Knock-in and flat plate. Both require adhering to the channel end. To keep water from submerging the glass we suggest drilling the thin end caps below the glass line with a min. 8mm hole or we can supply slotted versions. Other draining methods may need to be considered depending on the size of the balustrade and design.

6.

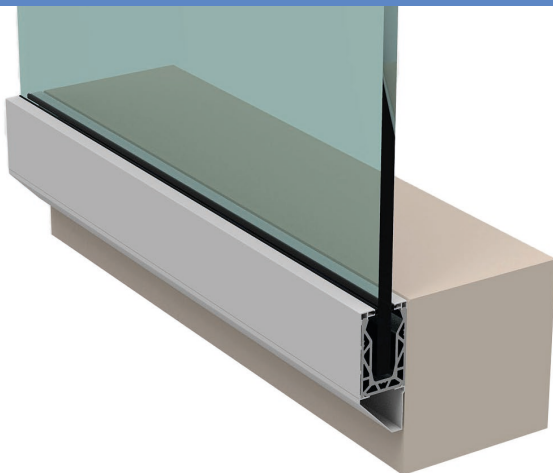

### FINISH INSTALLATION

Once everything is correctly in place, the glass and channel will need to be cleaned. Using a non-abrasive glass cleaner for the glass and warm soapy water for the channel. We recommend using a soft cloth to avoid scratches. Refer to the operating and maintenance manual for further maintenance.

Should any problems arise or you have any questions please don't hesitate to contact us:

T: +44 (0)1208 261 040

F: +44 (0)1208 261 041

E: sales@pure-vista.com

www.pure-vista.com