

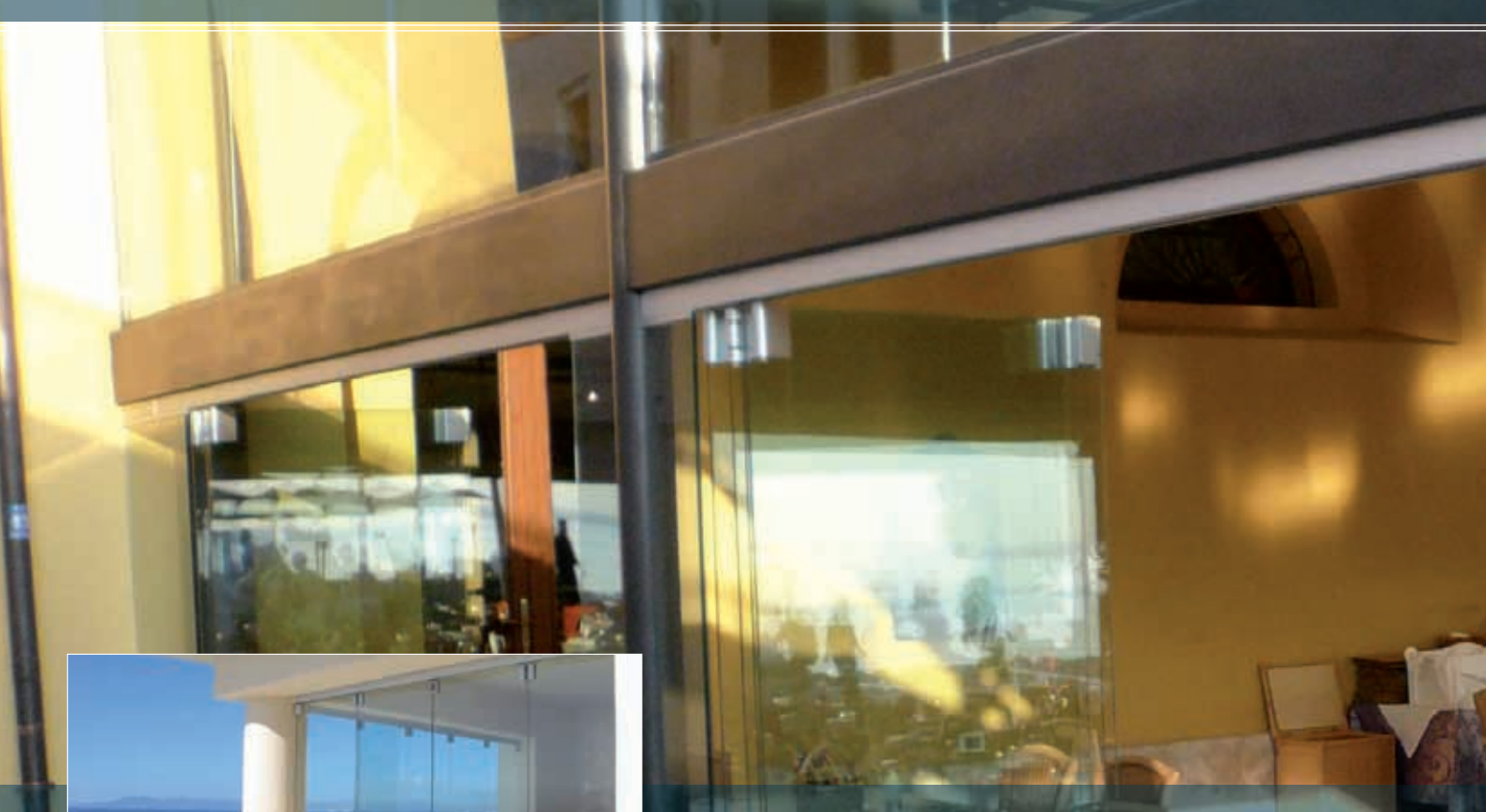

**invisible
connection**
by **CASMA**

Glass Wall



Alcune referenze - Some references - Algunas referencias

Bank One Center - Ohio, JFK Airport - New York, Austin Texas International Airport, Desoto Civic Center, Sotheby's Auction House - Rockefeller Center, Holiday Inn and Hilton Hotels, Benito Airport in Monterrey, Bilbao and Tenerife Airports, Munich Airport, North Carolina State Arena - Raleigh, RCA Dome - Indianapolis, Berlin World Trade Center, Berlin Sony Center, Zara Shopping Center - Croatia, Bombay Marriott Hotel, Audi showroom - Iglstadt, Peugeot showroom - Athens, Raffeybank - Türkenfeld, Opera Underground - Nürnberg, City Centre - Weiden, Courthouse - Memmingen, Isar Park office - Halbergmoos, Allee Beauty Parlour - Berlin, Training Centre - Waldheim Dresden, Federal Republic Chancellery - Berlin, World Trade Centre - Berlin, Schmutterpark Centre - Neusaess, Café Rischart - Munich, Ludwig's Passage - Augsburg, Luna-Princess-Palace - Unterschleißheim, Woort Company's Offices - Halberstadt, Höhenried Clinic - LVA Oberbayern, Commerzbank - Munich, Sparkassen Bank - Weilheim, Max Planck Company - Munich, Sozialdata - Munich, Schwarzer Adler Hotel - St. Anton Arlberg - Lucas Oil Stadium Indianapolis, etc.

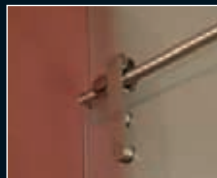
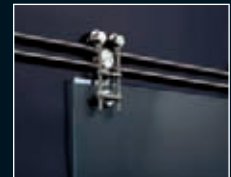
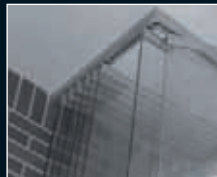

Technology by CASMA



Glass Wall Technology è la linea di accessori per sistemi di apertura in vetro temperato a scorrimento di **Casma**.

I prodotti che la compongono sono accomunati dall'utilizzo di parti metalliche ad angolo che danno il massimo spazio alla superficie vetrata rendendo quasi virtuale la barriera mobile.

I prodotti GWT trovano la loro applicazione ottimale all'interno di centri commerciali, aeroporti, ristoranti e dovunque sia necessario creare o rimuovere barriere. GWT è stata scelta dai progettisti in numerose realizzazioni di prestigio, alcune fra le quali estremamente innovative come le tribune VIP dei campi da baseball americani.



Glass Wall Technology is the line of hardware for tempered glass sliding systems by **Casma**.

All GWT products are brought together by the use of patch fittings metallic joints, which give the most possible space to the glass surface, making the mobile barrier nearly virtual.

GWT products find their ideal application in shopping centers, airports, restaurants and anywhere it's necessary to create or remove a barrier. GWT has been chosen by designers for countless prestigious buildings, some of which are extremely innovative, such as the VIP, suites at American baseball stadiums.

Glass Wall Technology es la línea de herrajes para sistemas de apertura de vidrio templado de deslizamiento de **Casma**.

Los productos que la componen tienen en común la utilización de partes metálicas no continuas que ofrecen el máximo espacio a la superficie acristalada haciendo casi virtual la barrera móvil. Los productos GWT son especialmente adecuados en centros comerciales, aeropuertos, restaurantes y dondequiera que sea necesario crear o eliminar barreras.

GWT ha sido elegida por los proyectistas de numerosas realizaciones de prestigio, entre las cuales se encuentran unas extremadamente innovadoras como las tribunas VIP de los campos de béisbol americanos.

invisible

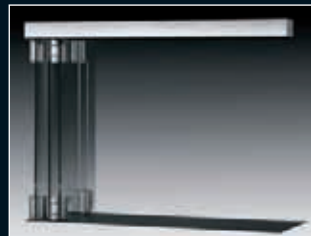
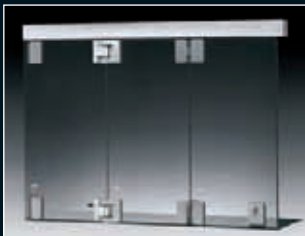

connection^{by} CASMA



Il sistema trova la propria applicazione nelle vetrate a libro, anche per questo prodotto è stato adottato un sistema di cerniere in alluminio scorrevoli e pieghevoli sempre nell'ottica di limitare al massimo la presenza di metalli sull'anta vetrata.

Il sistema scorre all'interno di una guida superiore e le ante trovano il proprio allineamento nella parte bassa grazie ad una guida di ottone nascosta nel pavimento.

Il sistema è disponibile in tutte le finiture dell'alluminio. Le dimensioni max di ogni anta sono 1000 x 3000 mm, con massimo 6 ante per lato, quindi 12 ante totali (per una larghezza complessiva del vano di 12000 mm). Gli spessori di vetro utilizzabili sono da 8 mm temperato a 10 mm+10 mm stratificato e temperato.

It is an innovative hardware system for frameless glass folding doors exclusively equipped with patch fittings.

The system hangs and slides in a top-mounted track and the wings are aligned in a "U" brass profile hidden in the floor. All the hardware is available only in aluminium and its finishes. Maximum size of each wing is 1000 x 3000 mm.

The maximum number of wings is 12 (for a total opening of 12000 mm) i.e. 6 wings on each side. Glass thickness from 8 mm for tempered glass up to 10+10 mm for tempered laminated glass.

El sistema se aplica en particular a puertas acristaladas a libro. Para este producto también se ha adoptado un sistema de bisagras de aluminio deslizables y plegables siempre con el objetivo de limitar lo más posibles la presencia de metales en la hoja de vidrio.

El sistema se desliza dentro de una guía superior y las hojas quedan alineadas en la parte baja gracias a un canal de latón escondido en el suelo.

El sistema se encuentra disponible en todos los acabados de aluminio. Las dimensiones máximas de cada hoja son de 1000 x 3000 mm, con máximo de 6 hojas por lado, y pues de 12 en total (por un ancho total de 12000 mm). Los espesores del vidrio utilizables son desde 8 mm con cristal templado hasta 10+10 mm con cristal laminado y templado.

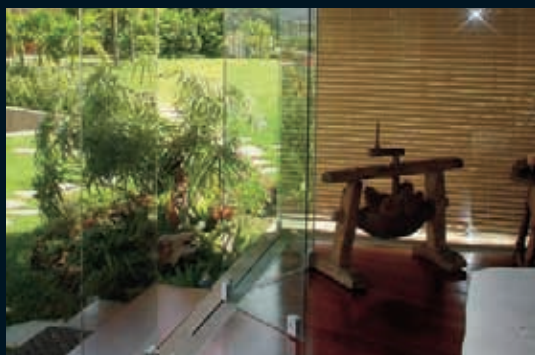

invisible



A richiesta soluzione alternativa
con rails alti 100 mm

Upon request alternative folding
solution with rails 100 mm high

Sobre pedido solución alternativa con zócalo
de altura de 100 mm

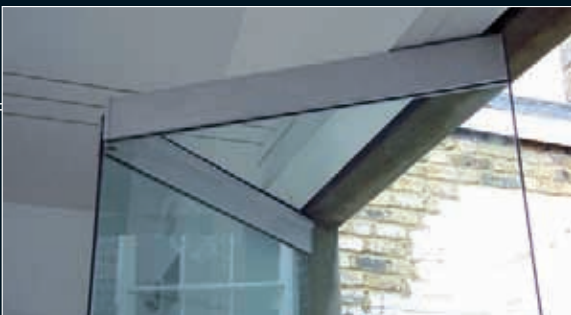

connection ^{by CASMA}



**invisible
connection**
by **CASMA**



componenti

components - componentes



8-006



Guida inferiore in ottone
(20x20x20x2mm)

Brass bottom rail
(20x20x20x2mm)

Guia inferior en latón
(20x20x20x2mm)

8-553



**Cerniera inferiore
completa di
catenaccio di
chiusura**

(impacchettamento interno)

Bottom patch fitting with
locking bolt
(folding inside)

Bisagra inferior completa
de cerrojo de cierre
(plegamiento al interior)

1-220



**Serratura a profilo
internazionale completa
di bocchetta a pavimen-
to senza cilindro**

Bottom lock international
profile complete with
floor strike no cylinder

Cerradura completa de
cerradero a pavimento
sin cilindro

8-554



**Cerniera inferiore per
prima/ultima anta**

Bottom patch fitting for
leading wing

Bisagra inferior para la
primera/última hoja

8-550



**Cerniera
superiore/inferiore**

Top/bottom patch fitting
Bisagra superior/inferior

8-555



**Cerniera inferiore di
scorrimento**

Bottom sliding patch
fitting

Bisagra inferior de
deslizamiento

componenti

components - componentes

8-561



Cerniera superiore di scorrimento

Top sliding patch fitting
Bisagra superior de deslizamiento

8-564



Cerniera inferiore destra o sinistra completa di catenacciolo di chiusura

(impacchettamento esterno)

Left or right bottom patch fitting with locking bolt
(folding outside)

Bisagra inferior derecha o izquierda completa de cerrojo de cierre
(plegamiento al exterior)

8-562



Cerniera superiore per ultima anta

Top patch fitting for last wing
Bisagra superior para la última hoja

8-700



Guida superiore in alluminio

Aluminium upper track
Guía superior en aluminio

8-563



Alloggiamento per cerniera inferiore prima/ultima anta art. no. 8-554

Bottom pivot adaptor for leading wing patch fitting
art. no. 8-554

Alojamiento para la bisagra inferior primera/última hoja art. no. 8-554

8-567



Bloccaggio di scorrimento per prima/ultima anta

Upper stop for leading wing's roller

Blocaje de deslizamiento para primera/última hoja

8-560



Cerniera superiore per prima anta

Top patch fitting for first wing
Bisagra superior para la primera hoja

**invisible
connection**
by **CASMA**

instal



lazioni complete

complete installations - instalaciones completos



Art. N° 8-511

Installazione ad anta singola composta dagli articoli:

One wing installation composed by the articles:
 Instalación con una sola hoja compuesta de los artículos:

Art.	8-006	8-554	8-560	8-563	8-700	8-567	1-220
Q.ty	01	01	01	01	01	01	01

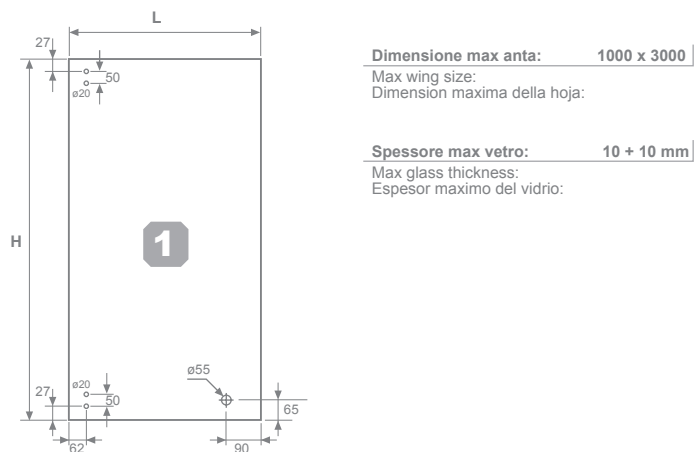
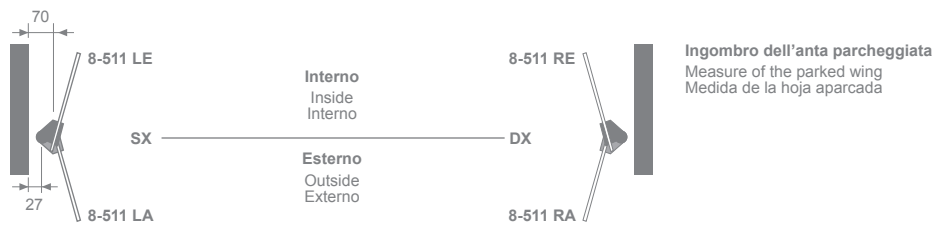
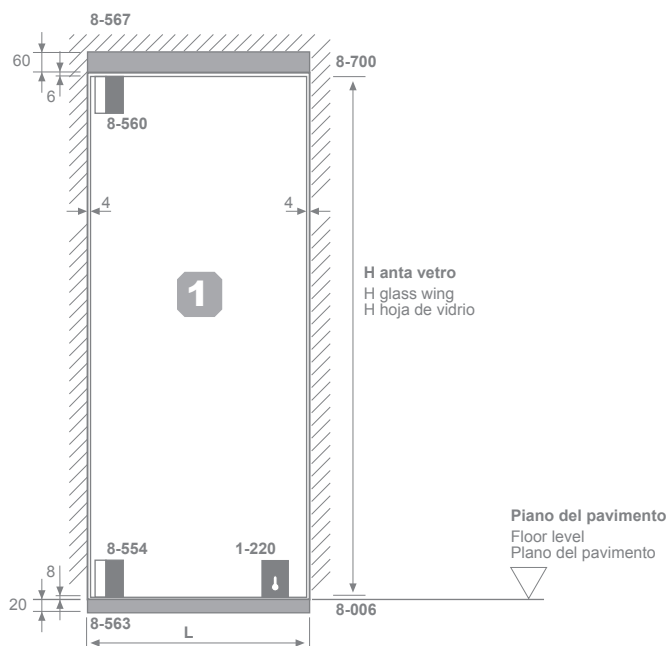

Infoline

+39 02 97298418

per maggiori informazioni consultateci

for more information consult us
 para mayor informacion consultar

Art. N° 8-512

Installazione a due ante composta dagli articoli:

Two wings installation composed by the articles:
 Instalación con dos hojas compuesta de los artículos:

Art.	8-006	8-550	8-553	8-564	8-554	8-562	8-563	8-700	8-567	8-560
Q.ty	01	01	01	01	02	01	01	01	01	01

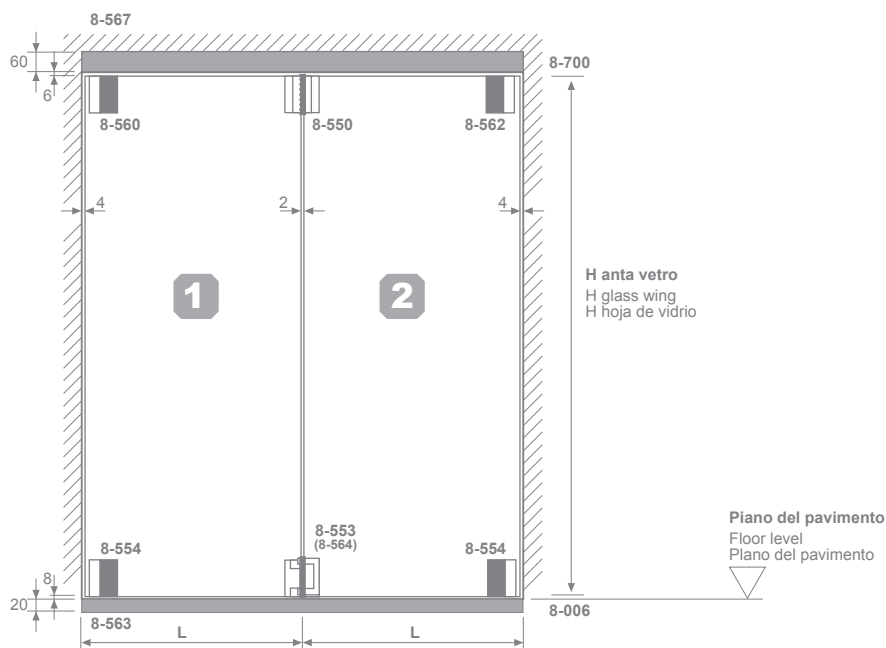

Lunghezza della guida superiore e a pavimento per ordini a stock	8-700	2000 mm
	8-006	2000 mm

Upper track and bottom "U" channel length for stock orders

Ancho de las guías superior y inferior para pedido de stock



Ingombro dell'anta parcheggiata
 Measure of the parked wing
 Medida de la hoja aparcada

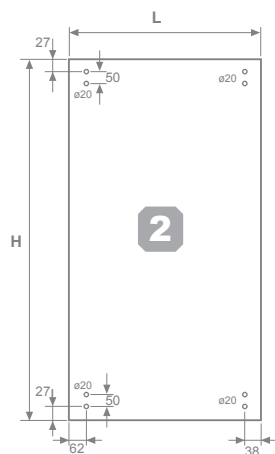

Dimensione max anta: 1000 x 3000

Max wing size:
 Dimension maxima della hoja:

Spessore max vetro: 10 + 10 mm

Max glass thickness:
 Espesor maximo del vidrio:

Per il posizionamento della serratura vedere pag. 25
 For the lock positioning see page 25
 Por alojamiento de la cerradura ver pag. 25

Art. N° 8-513

Installazione a tre ante composta dagli articoli:

Three wings installation composed by the articles:
 Instalación con tres hojas compuesta de los artículos:

Art.	1-220	8-006	8-550	8-553	8-564	8-554	8-555	8-561	8-560	8-563	8-700	8-567
Q.ty	01	01	01	01	01	01	01	01	01	01	01	01

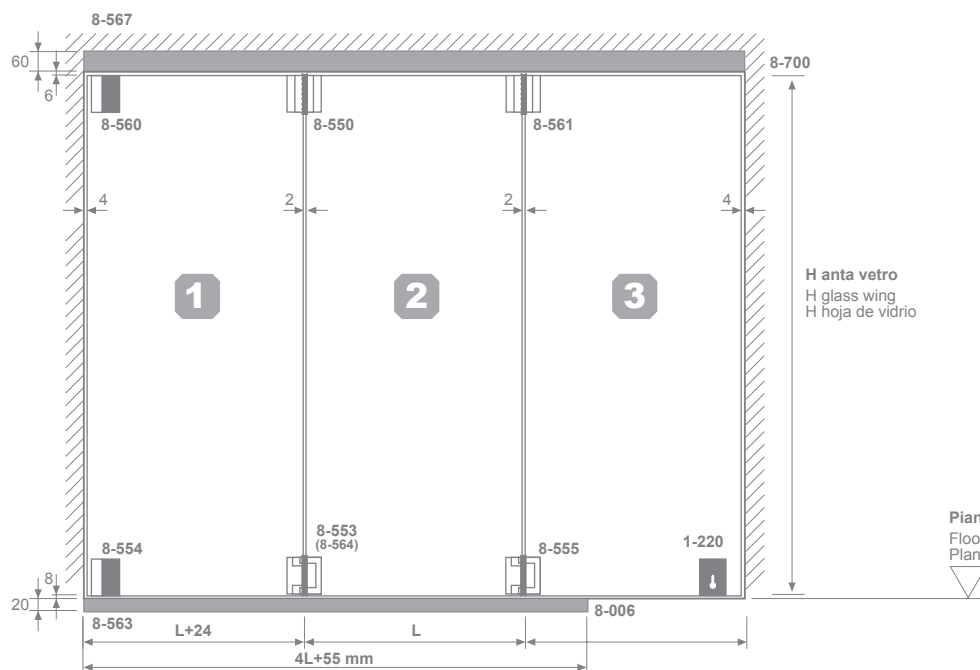

Lunghezza della guida superiore e a pavimento per ordini a stock	8-700	3000 mm
	8-006	3000 mm

Upper track and bottom "U" channel length for stock orders

Ancho de las guías superior y inferior para pedido de stock

H anta vetro
 H glass wing
 H hoja de vidrio

Piano del pavimento
 Floor level
 Plano del pavimento

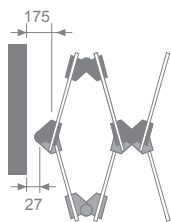

8-513 LE

SX

8-513 LA

Interno
 Inside
 Interno

Esterno
 Outside
 Externo

8-513 RE

DX

8-513 RA

Ingombro dell'anta parcheggiata
 Measure of the parked wing
 Medida de la hoja aparçada

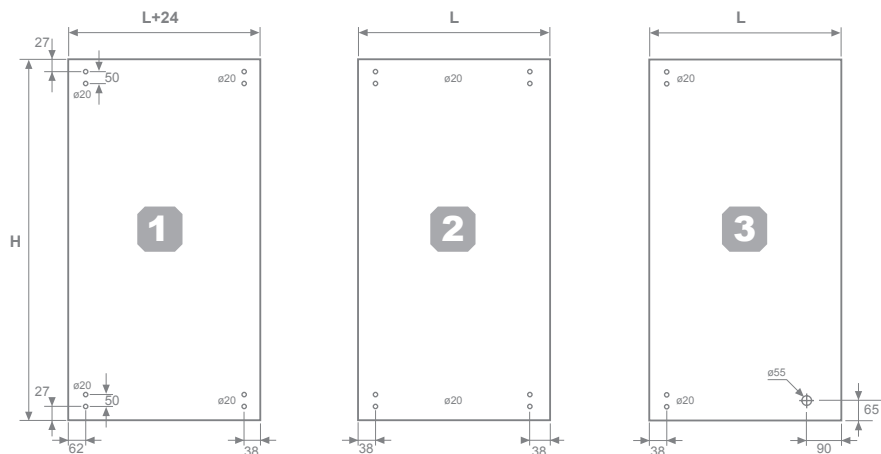

Dimensione max anta: 1000 x 3000

Max wing size:
 Dimension maxima della hoja:

Spessore max vetro: 10 + 10 mm

Max glass thickness:
 Espesor maximo del vidrio:

Infoline

+39 02 97298418

per maggiori informazioni consultateci

for more information consult us
 para mayor informacion consultar

Art. N° 8-514

Installazione a quattro ante composta dagli articoli:

Four wings installation composed by the articles:
 Instalación con cuatro hojas compuesta de los artículos:

Art.	8-006	8-550	8-553	8-564	8-554	8-555	8-561	8-562	8-563	8-700	8-567	8-560
Q.ty	01	02	02	02	02	02	01	01	01	01	01	01

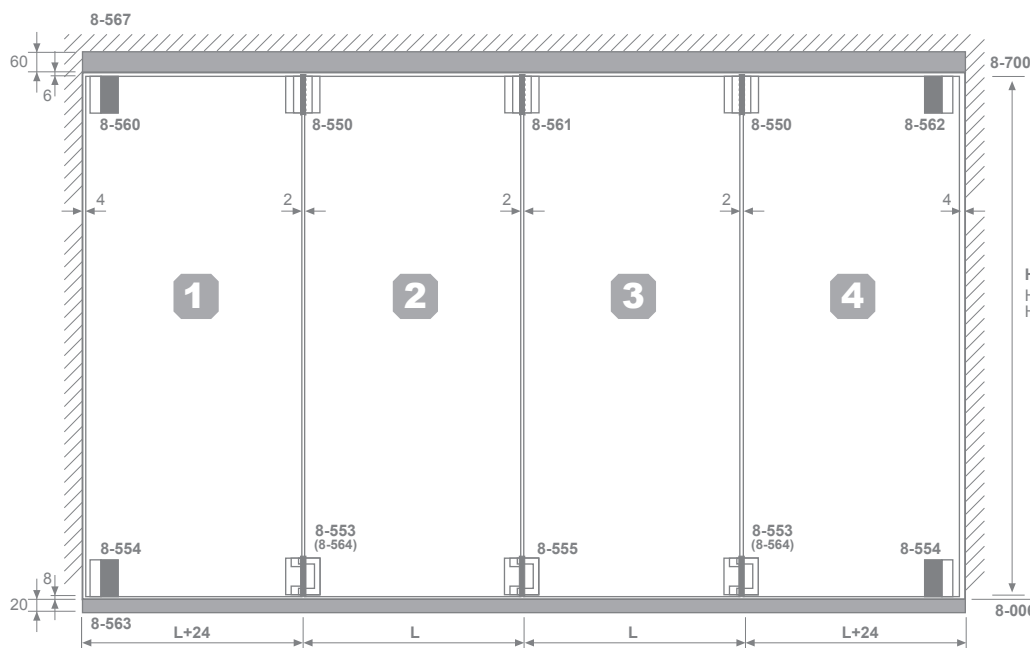

Lunghezza della guida superiore e a pavimento per ordini a stock	8-700	4000 mm
	8-006	4000 mm

Upper track and bottom "U" channel length for stock orders

Ancho de las guías superior y inferior para pedido de stock

H anta vetro
 H glass wing
 H hoja de vidrio

Piano del pavimento
 Floor level
 Plano del pavimento

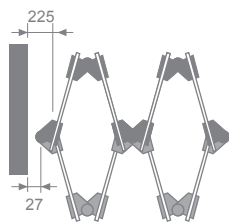

8-514 LE

8-514 LA

Interno
 Inside
 Interno

Esterno
 Outside
 Externo

SX

8-514 RE

8-514 RA

DX

Ingombro dell'anta parcheggiata
 Measure of the parked wing
 Medida de la hoja aparçada

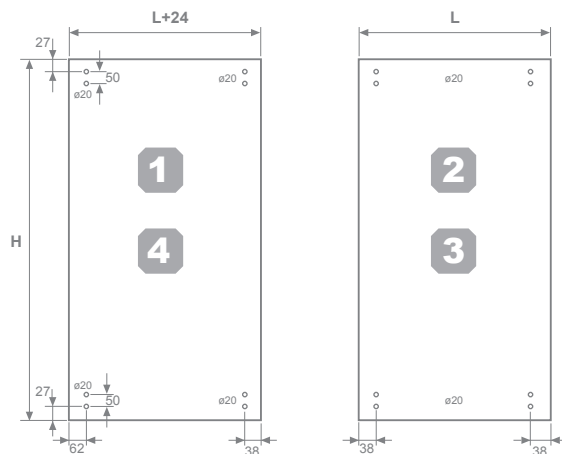

Dimensione max anta: 1000 x 3000

Max wing size:
 Dimension maxima della hoja:

Spessore max vetro: 10 + 10 mm

Max glass thickness:
 Espesor maximo del vidrio:

Per il posizionamento della serratura vedere pag. 25

For lock positioning see page 25
 Por alojamiento de la cerradura ver pag. 25

Art. N° 8-515

Installazione a cinque ante composta dagli articoli:

Five wings installation composed by the articles:
 Instalación con cinco hojas compuesta de los artículos:

Art.	1-220	8-006	8-550	8-553	8-564	8-554	8-555	8-561	8-560	8-563	8-700	8-567
Q.ty	01	01	02	02	02	01	02	02	01	01	01	01

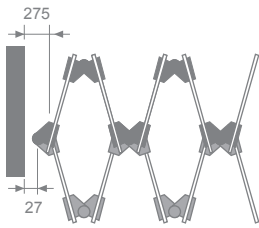
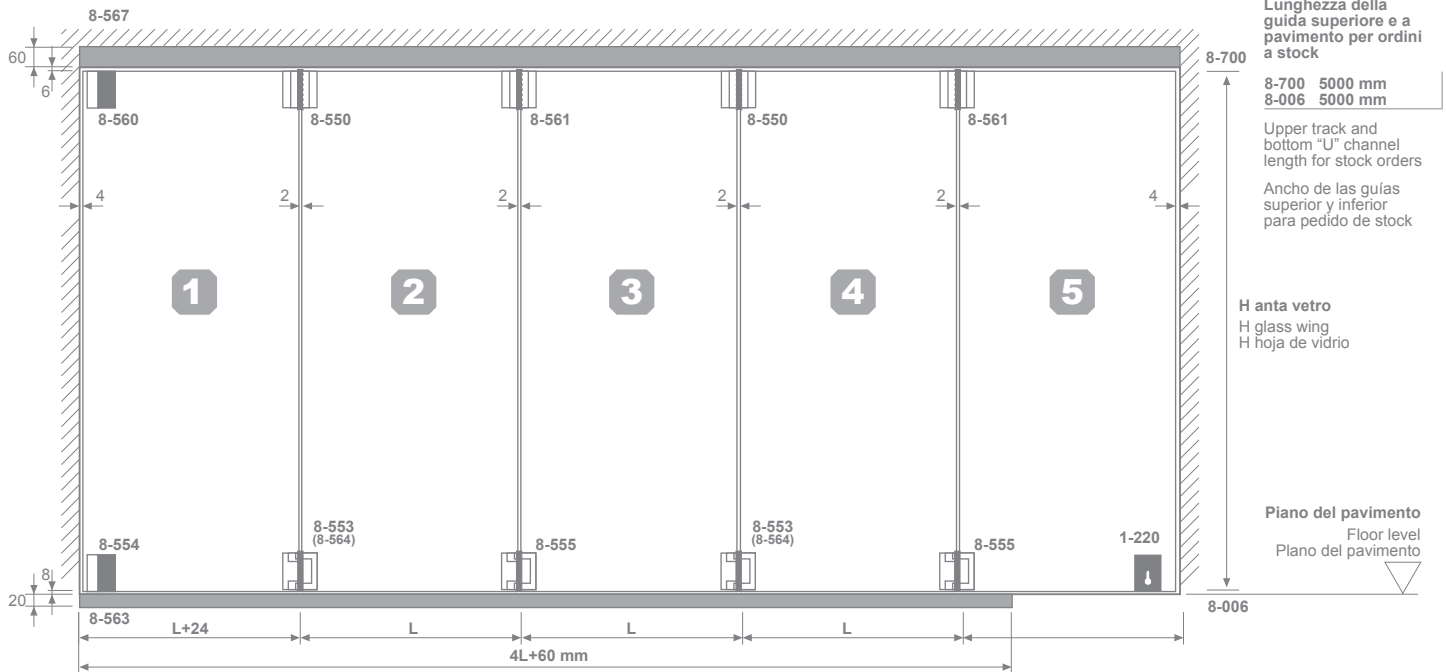

8-515 LE
SX
8-515 LA

Interno
Inside
Interno
Esterno
Outside
Esterno

8-515 RE
DX
8-515 RA

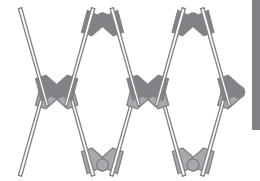

Ingombro dell'anta parcheggiata
Measure of the parked wing
Medida de la hoja aparcada

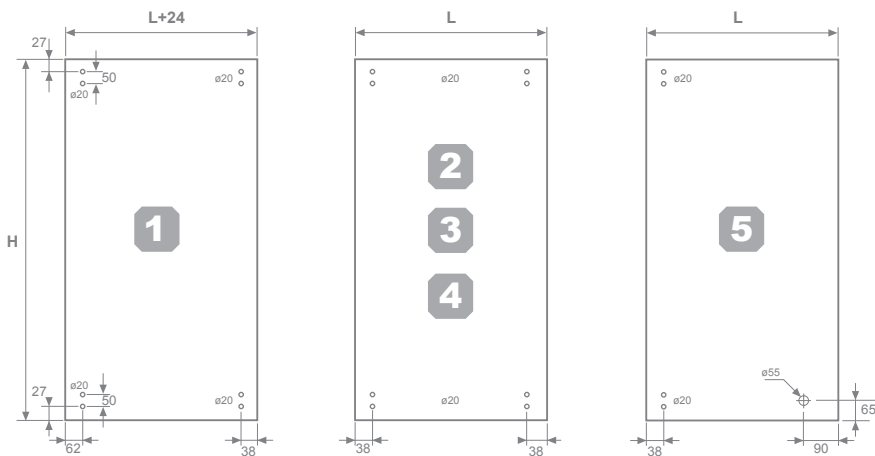

Dimensione max anta: 1000 x 3000

Max wing size:
Dimension maxima della hoja:

Spessore max vetro: 10 + 10 mm

Max glass thickness:
Espesor maximo del vidrio:

Infoline

+39 02 97298418

per maggiori informazioni consultateci

for more information consult us
para mayor informacion consultar

Cambiamo per migliorare

We change to improve

Cambiamos para mejorar

1 Velocità e semplicità di installazione

Easier and faster installation

Facilidad y rapidez en la instalacion

2 Dimensioni max dell'anta

1000X3000mm = + 20%

Max dimensions of the glass panel

1000X3000mm = +20%

Medidas máx. de la hoja 1000X3000mm = + 20%

3 Invisible Connection e Junior hanno la stessa guida superiore = vantaggi nello stoccaggio dei due sistemi

Invisible Connection and Junior have same upper track = stock advantages for both systems.

Invisible Connection y Junior tienen la misma

guía superior = menos stock para los dos sistemas.



**invisible
connection**
by **CASMA**



sezione tecnica

technical section - sección técnica



Sezione orizzontale

Horizontal section
Seccion horizontal

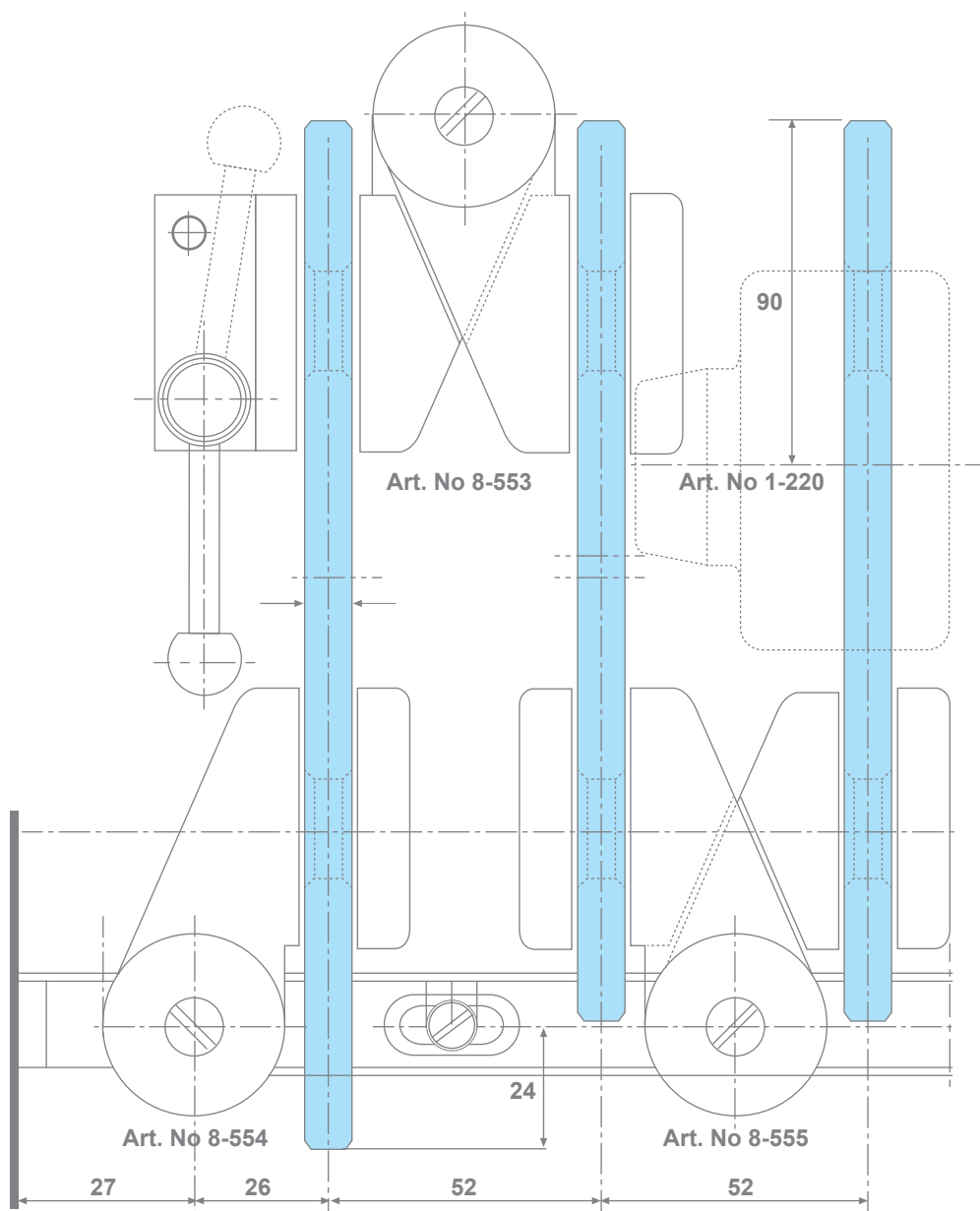

sezione tecnica

technical section - sección técnica

Sezione verticale superiore

Upper vertical section
Sección vertical superior

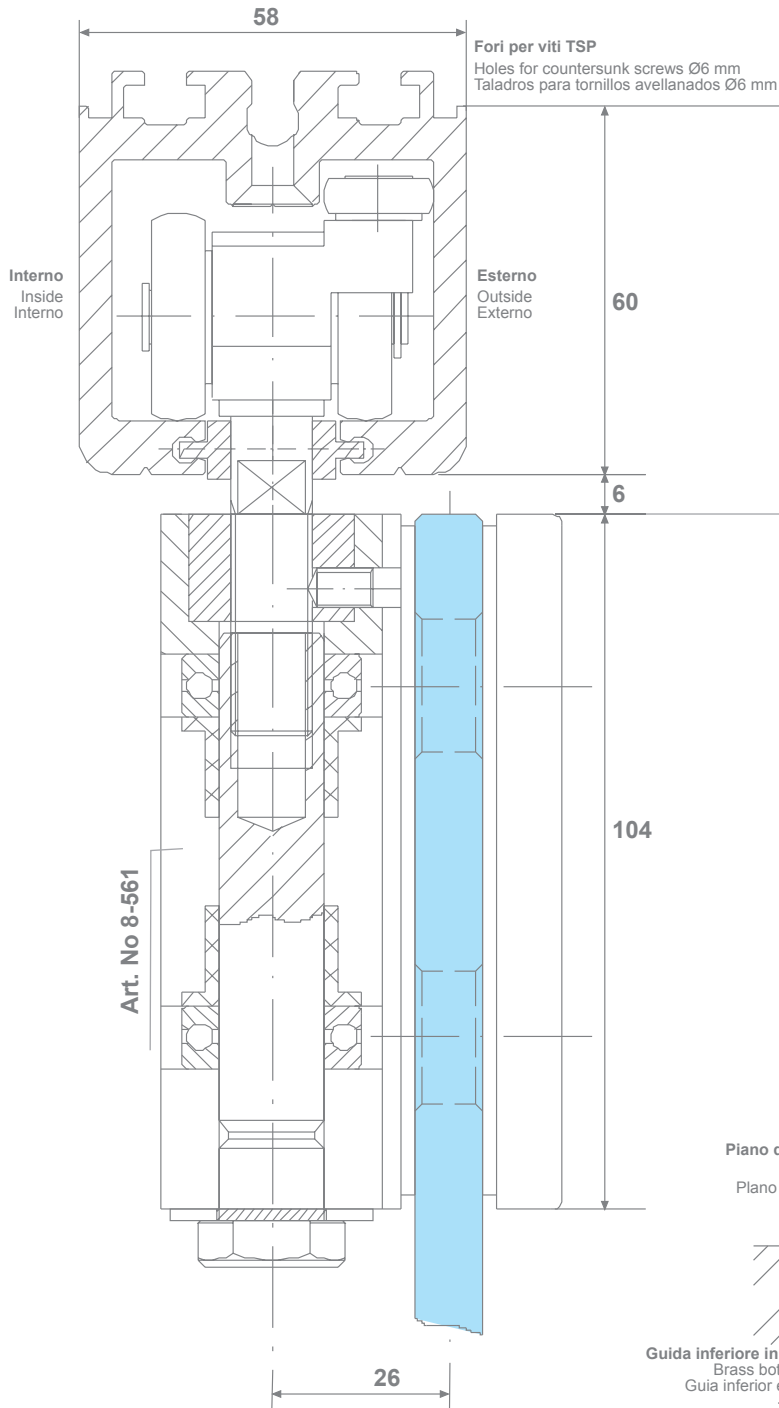

Sezione verticale inferiore

Bottom vertical section
Sección vertical inferior

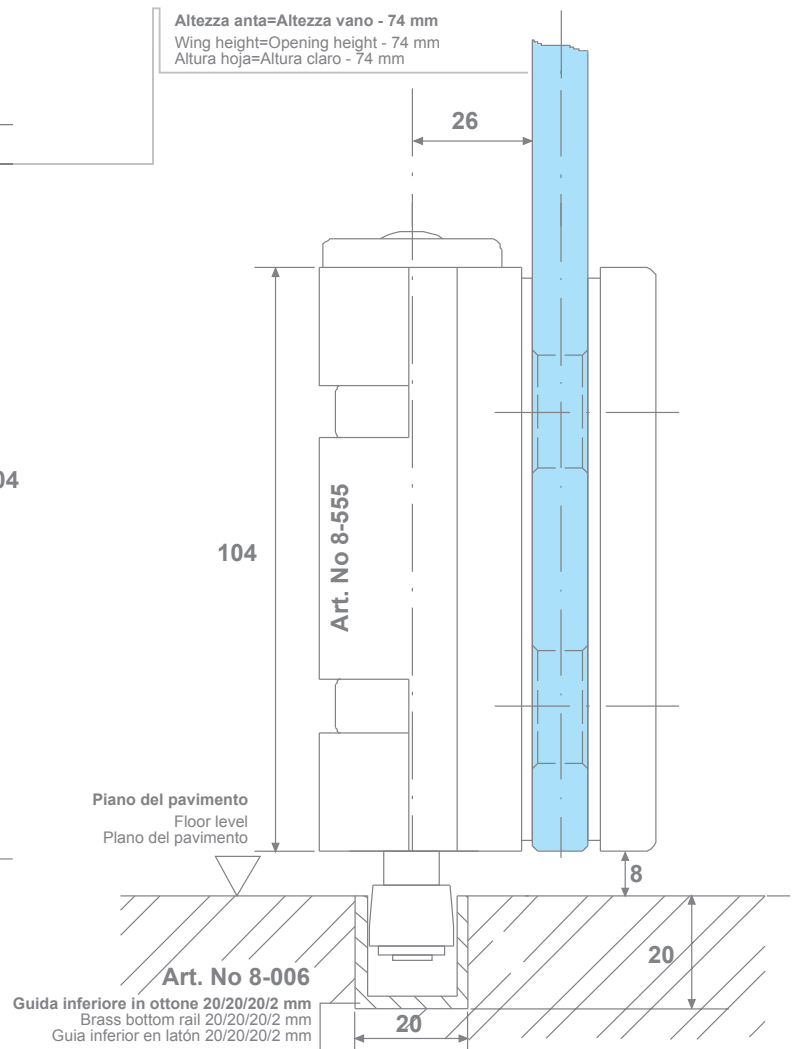

Dettaglio superiore della prima anta

Upper detail of first wing
Detalle superior de la primera hoja

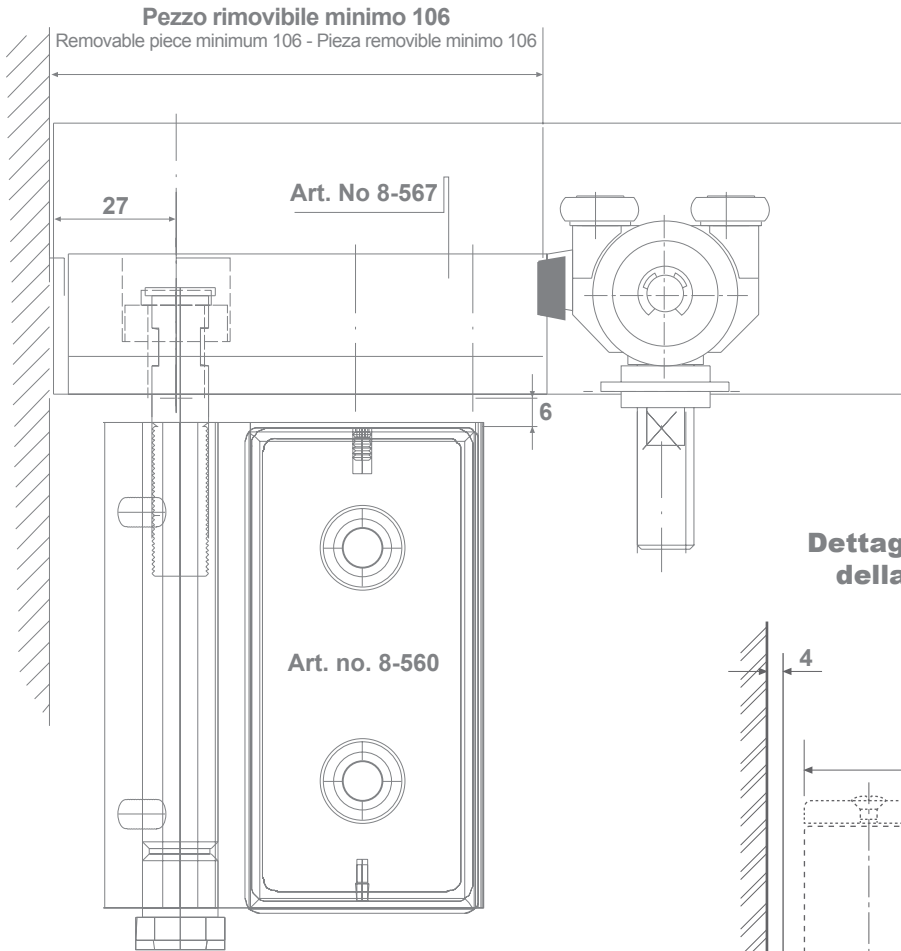

Dettaglio inferiore della prima anta

Bottom detail of first wing
Detalle inferior de la primera hoja

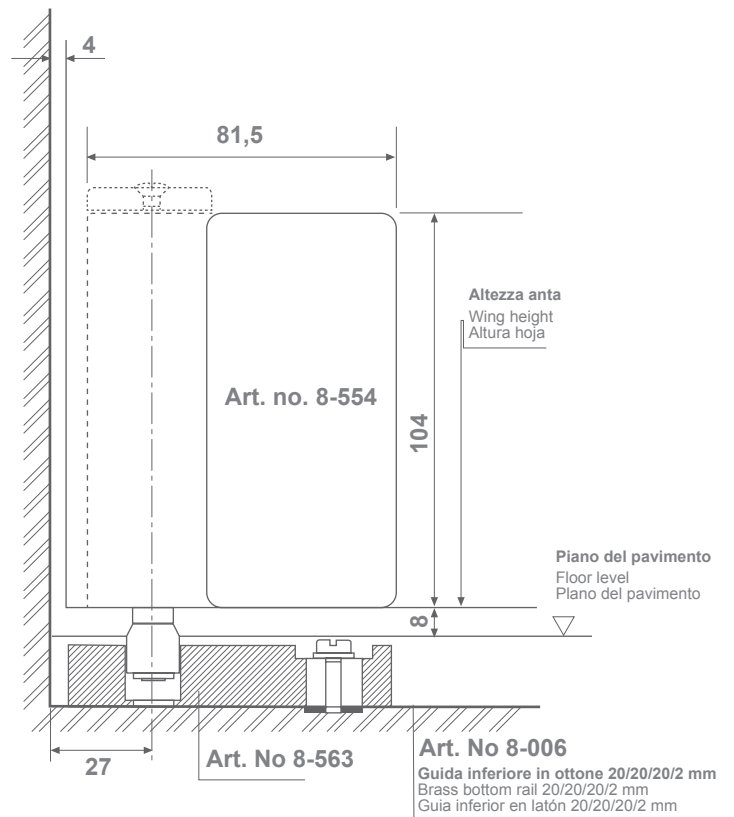

sezione tecnica

technical section - sección técnica

Art. N° 8-512
Art. N° 8-514
Art. N° 8-516
Posizionamento
della serratura esterna

Positioning of the external lock
 Alojamiento de la cerradura externa

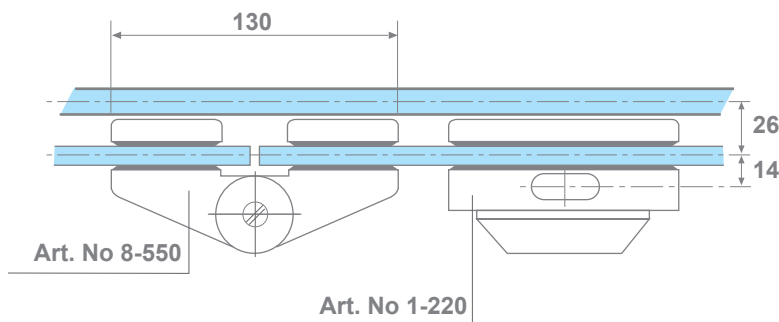
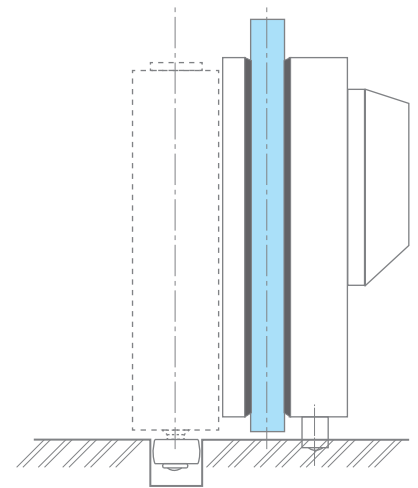
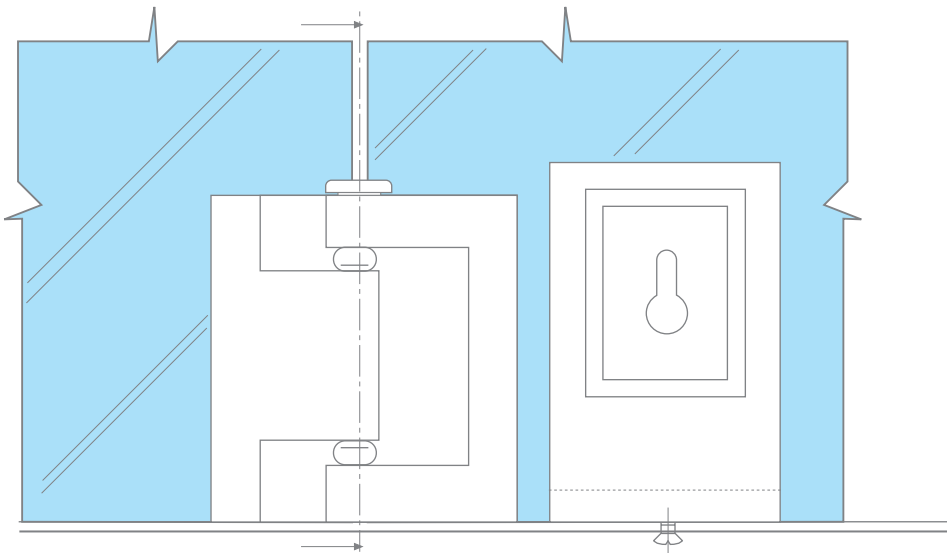

Posizionamento della serratura (Art. N° 1-220)
 nel caso di installazioni a 2, 4 o 6 ante che necessitano
 l'accesso alla chiusura dall'esterno.

Positioning of the lock (Art. N° 1-220) in case of installations of 2, 4 or 6 wings where locking is required from the outside.
 Alojamiento de la cerradura (Art. N° 1-220) en el caso de instalaciones de 2, 4 o 6 hojas que necesitan cerrar desde el exterior.

IMPORTANTE: La serratura Art.1-220 sarà posizionata come da disegno sostituendo l'accessorio Art. N° 8-553 con l'Articolo 8-550.

IMPORTANT: The lock item 1-220 has to be placed according to the above drawing replacing the fitting Art. N° 8-553 with the fitting Art. N° 8-550.

IMPORTANTE: La cerradura Art. No. 1-220 se instalará como el diseño sustituyendo el accesorio Art. N° 8-553 con el accesorio Art. N° 8-550.

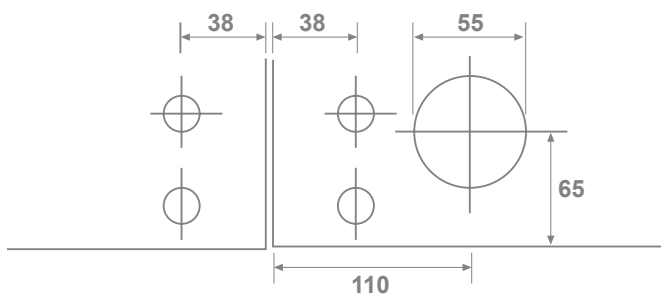

Disposizione carrelli nella guida superiore

Rollers positioning in the upper track
Alojamiento carretillas en la guía superior

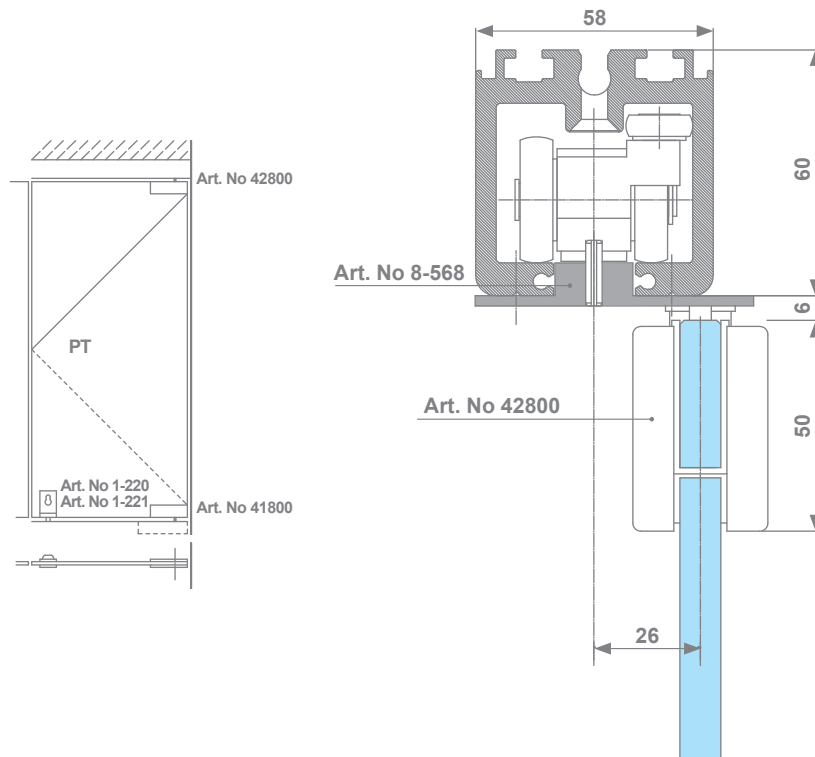
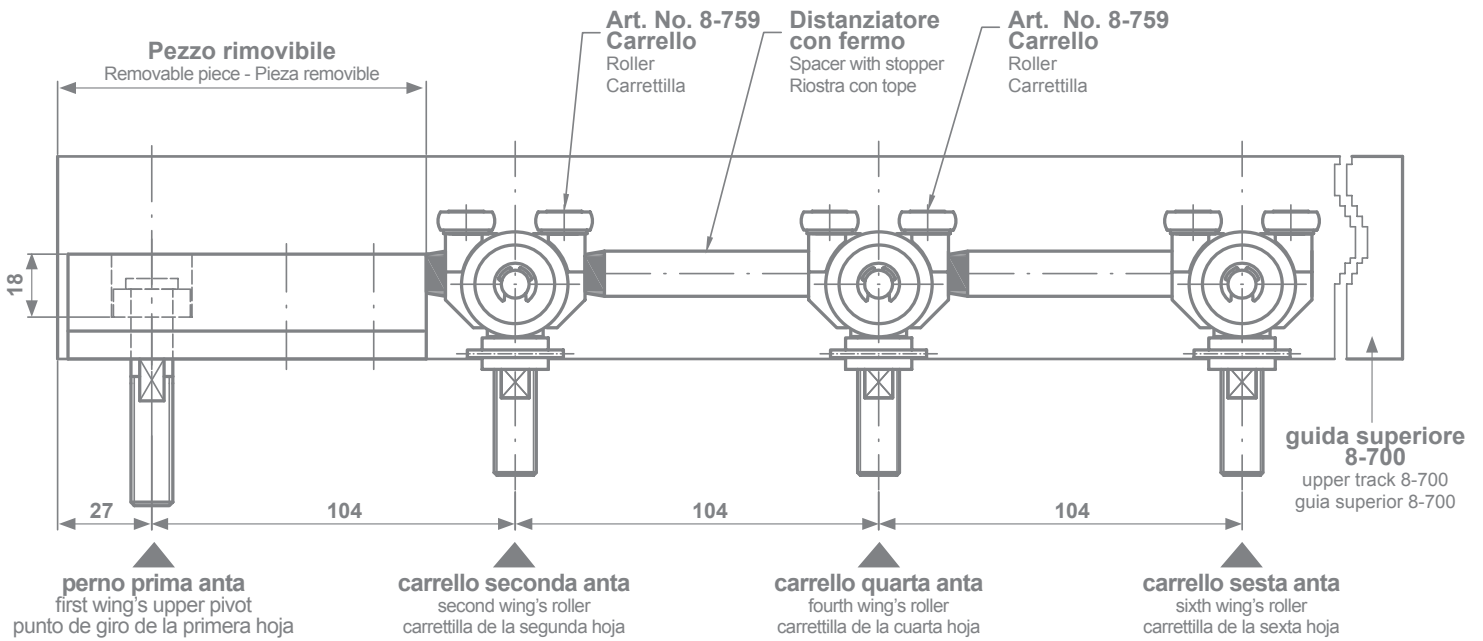





CASMA S.p.A.

Via Primo Maggio, 86 - 20013 **MAGENTA** (MI) - Italy
ph. +39 02 97298418 - fax +39 02 97299006
www.casma.com - casma@casma.it

02.08.03