

M68

speedy
by CASMA®

speedy

by CASMA®

M68

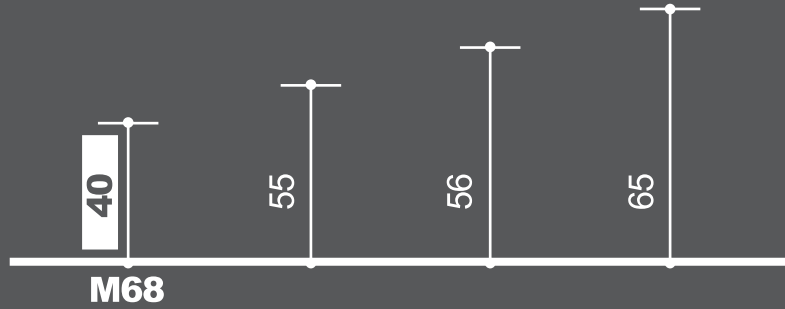

Back-stop a 120°
Back stop 120°
Back-stop a 120 grados

Fermo
Hold-open
Retención

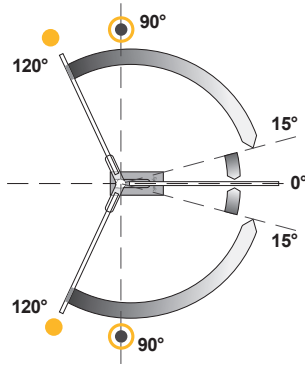

EN-3

Forza Rossa
(Red Strength,
Fuerza Roja)

max 950

**Peso della porta
sostenibile 100kg**

Door weight up to
100kg

Peso de la puerta
sostenible 100kg

Finiture

Finishes
Acabados



Acciaio
Stainless Steel
Acero



1 Tutte le teste di
perno internazionali
All kind of International
spindles heads
Levas disponibles en
todas las gamas
internacionales

5 Valvola di sicurezza
Safety valve
Válvula de seguridad

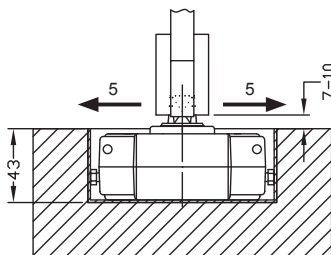
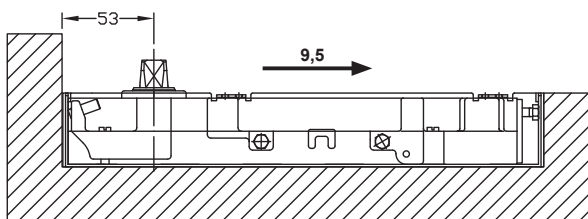
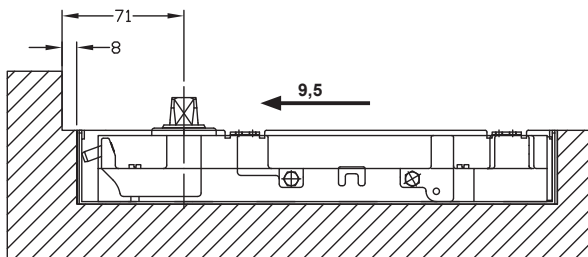
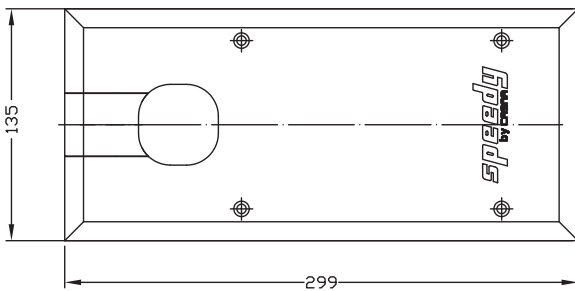
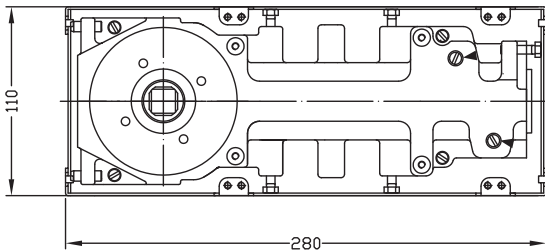



EN1154 Tested



2 Fusione in ghisa
Cast Iron body
Fusión en hierro



3 Tassello del coperchio in finitura
Cover in two pieces in the same finishes
Tapita en acabado de la tapa



4 Posizione del coperchio regolabile
Adjustable cover position
Posición de la tapa regulable

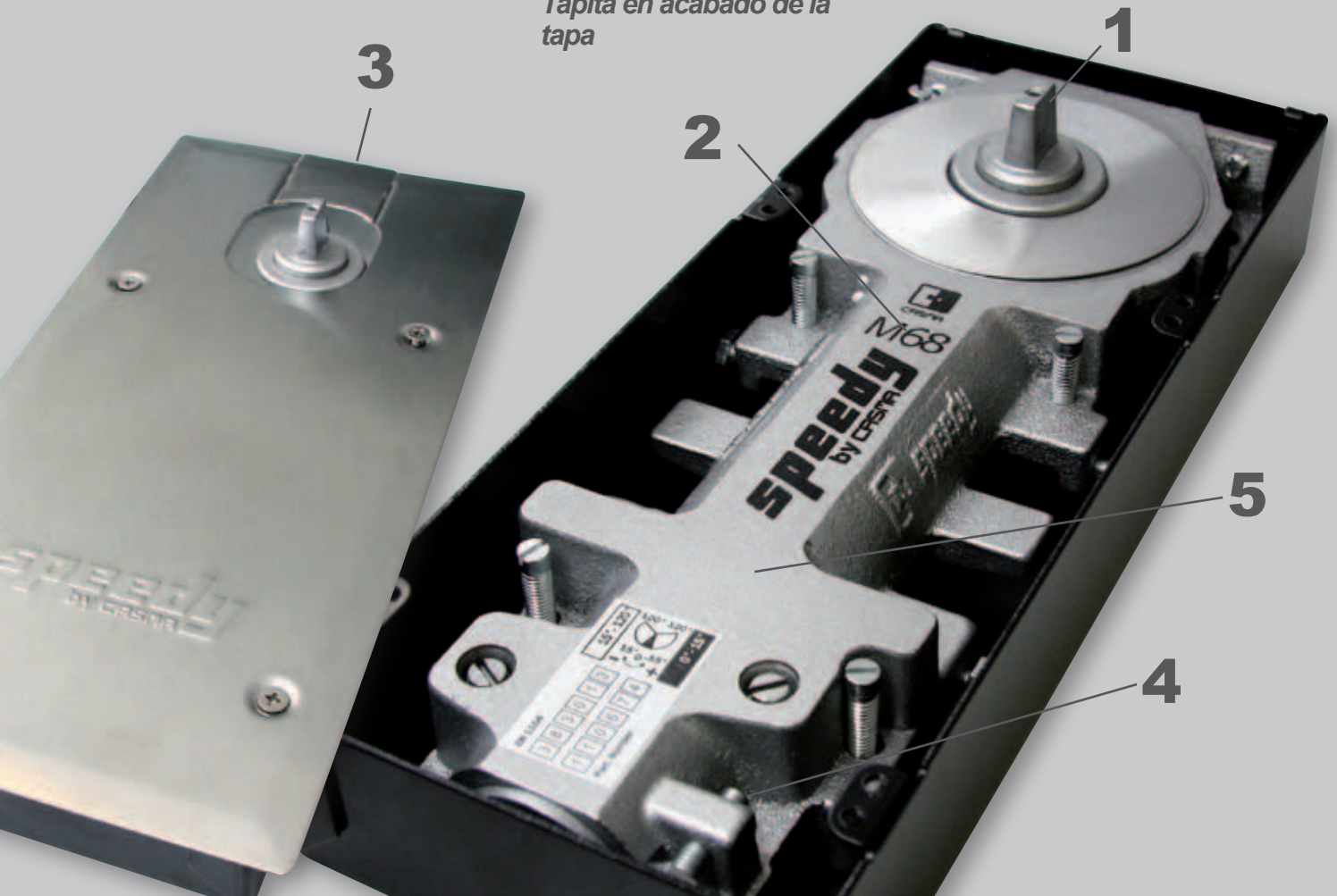

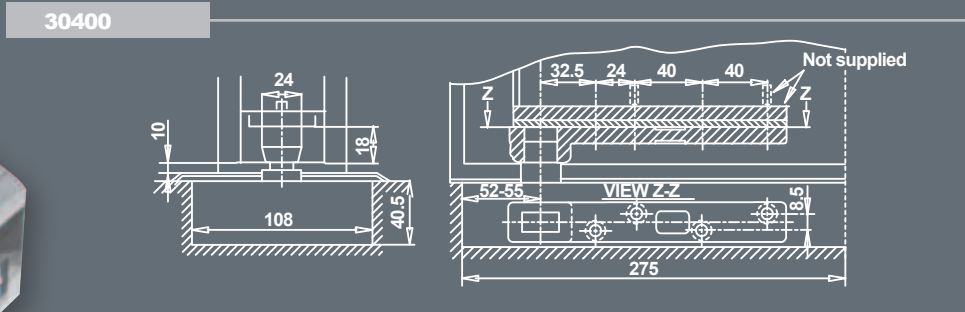
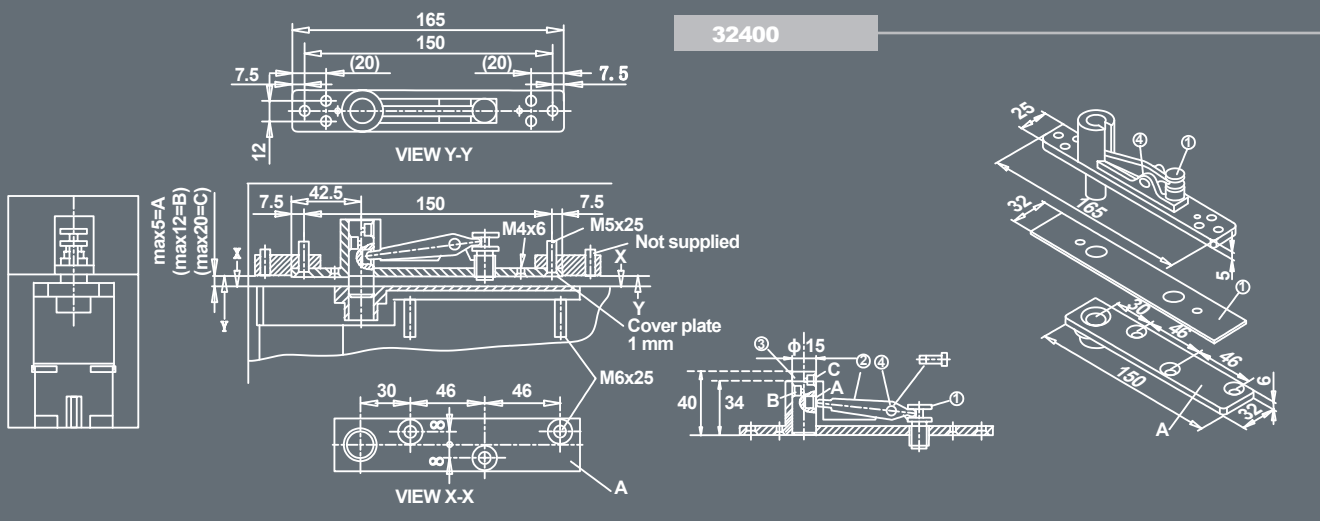

speedy
byCASMA®

CASMA S.p.A.

Via Primo Maggio, 86 - 20013 **MAGENTA** (MI) - Italy
ph. +39 02 97298418 - fax +39 02 97299006
www.casma.com - casma@casma.it