

Pico
by **CASMA**

Glass Wall



Technology

PICO è un sistema destinato a completare le linea di scorrevoli monoguida per ante in vetro temperato. Gli accessori ed i carrelli di scorrimento, di dimensioni molto ridotte, sono nascosti nella guida superiore. Esistono due tipologie differenti di guide superiori: con o senza predisposizione per i pannelli fissi laterali. La novità di PICO consiste nella possibilità di installazione e manutenzione dell'anta in vetro dal basso, ideale per l'applicazione della guida nascosta nei controsoffitti. Il sistema prevede in esecuzione standard un vetro di spessore massimo 12mm ed un peso massimo dell'anta di 150kg. PICO richiede due piccole lavorazioni sull'anta di vetro in prossimità di ciascuno dei carrelli di scorrimento.

PICO es un sistema pensado para completar la línea de correderas de una sola guía para puertas de cristal templado. Los accesorios y las guías de deslizamiento, de dimensiones muy reducidas, están ocultas en la guía superior. Existen dos tipologías diferentes de guía superior: con o sin preparación para los paneles fijos laterales. La novedad de PICO consiste en la posibilidad de instalación y mantenimiento de la puerta de cristal desde abajo, ideal para el montaje de la guía oculta en los cielos falsos. El sistema prevé como instalación standard un cristal de espesor máximo de 12 mm y un peso máximo de la puerta de 150 kg. PICO requiere dos pequeñas muescas en la puerta de vidrio en la proximidad de cada una de las guías de deslizamiento.

PICO is a further evolution in the glass sliding system product range. The upper track of PICO is available in two different versions with and without side fixed panel. The set of clamps and stoppers are very small and totally hidden in the upper track. Pico is an ideal solution for false ceiling installation. In fact the glass panel can be easily hung and adjusted from below the false ceiling level. Glass panel weight should not exceed 150Kg and 12mm thickness. Glass cut outs are required to assure maximum security.



Vetrografica Vallati - ROMA

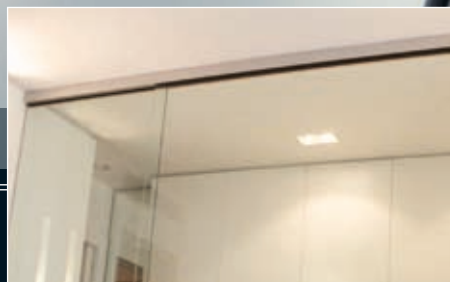

Vetreteria Riccionese - RI

Installazioni tipo - Installation types - Tipos de instalaciones

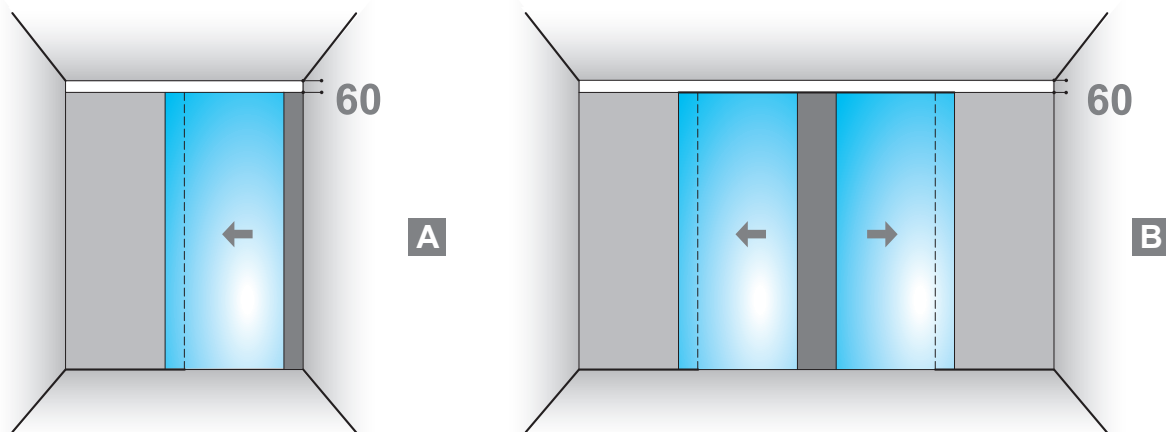

La guida superiore di scorrimento prevede 2 metodi di fissaggio: uno frontalmente a parete (fig.1.1) ed uno a soffitto (fig.1.2).

The upper runner rail has 2 fastening possibilities: one opposite to wall (fig.1.1) and one to ceiling (fig.1.2).

La guía superior de deslizamiento prevé dos tipos de su-fijación: uno frontal a la pared (fig. 1.1) y uno al techo (fig.1.2).

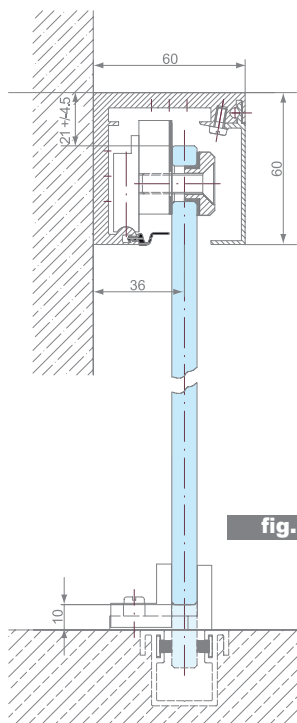

fig. 1.1

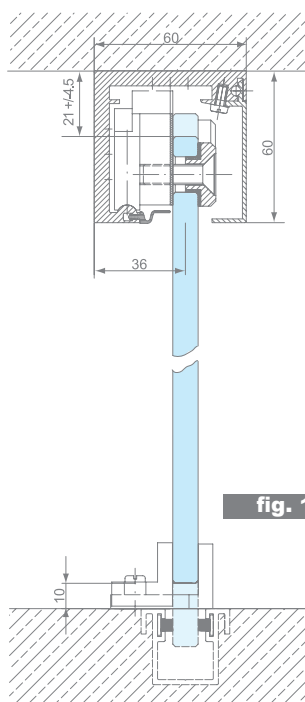
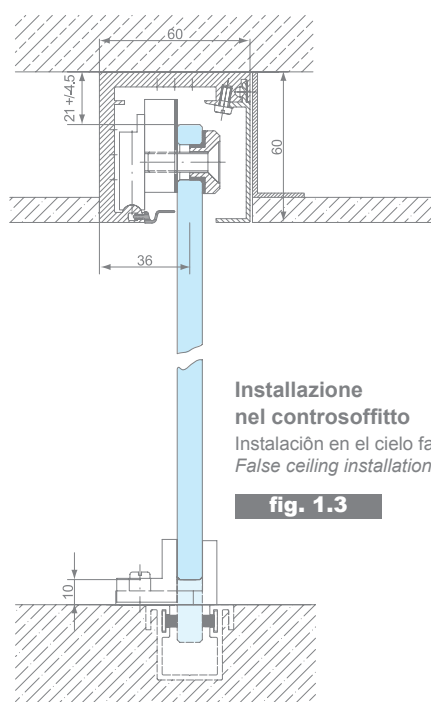

fig. 1.2



Installazione nel controsoffitto
 Instalación en el cielo falso
 False ceiling installation

fig. 1.3

sezione tecnica

technical section - sección técnica

Art. 4-507

Guida di scorrimento con contropiastra (fig. 1.4) di fissaggio al sopra-luce.

Connection plate (fig. 1.4) for fixing the runner rail to the overpanel.

Guía de deslizamiento completa de contraplaca para fijar al montante (fig. 1.4).

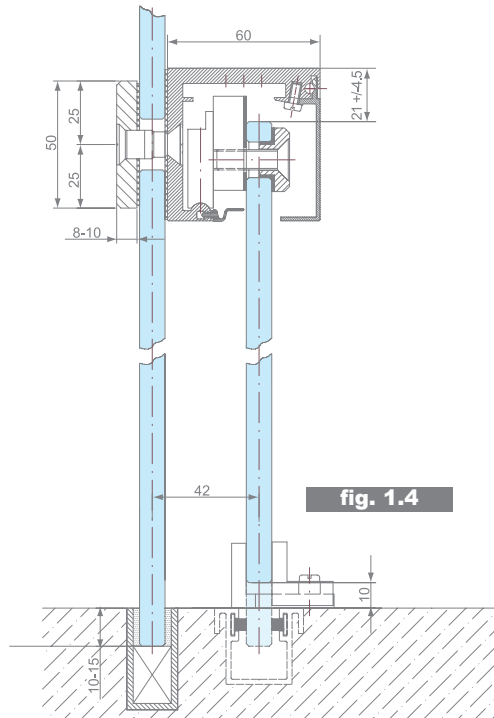
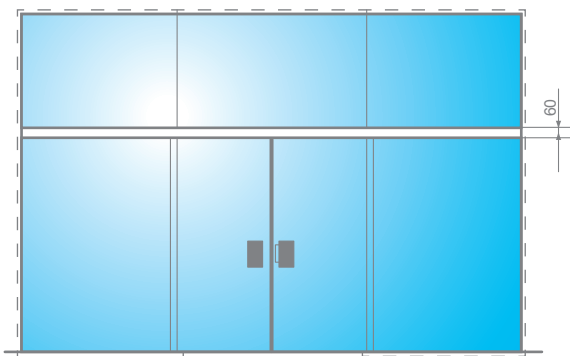

Tacche - Glass cut out - Muestras en el vidrio

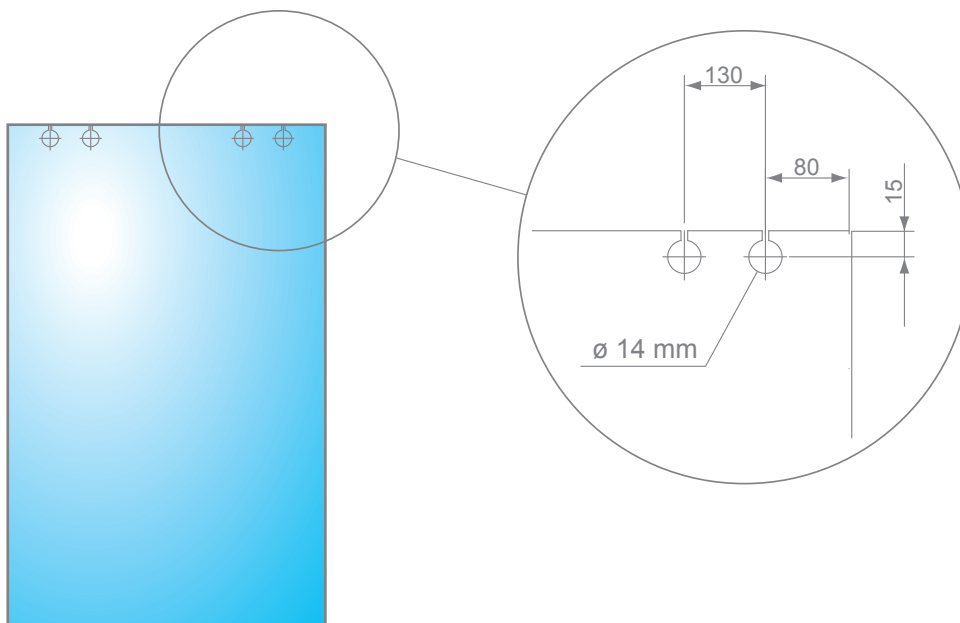

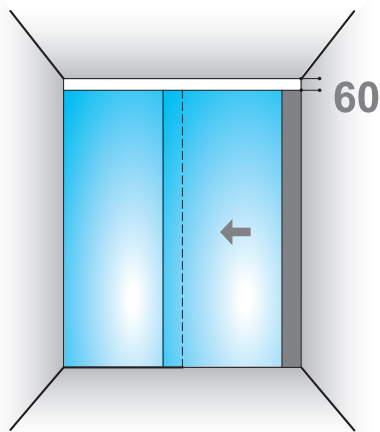

C

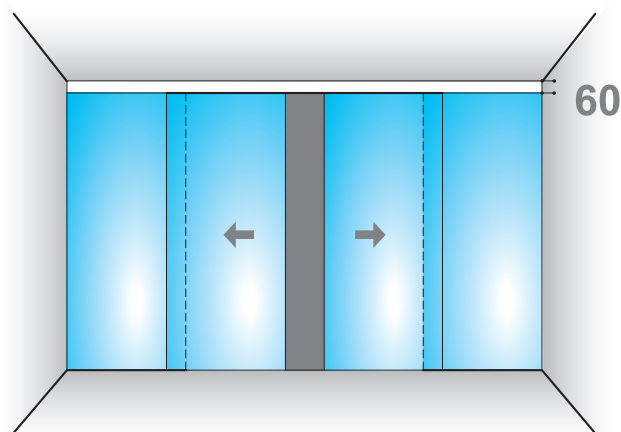

D

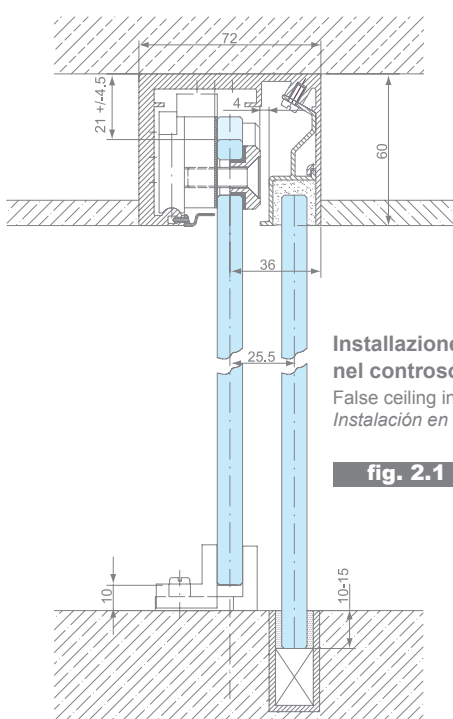

**Installazione
nel controsoffitto**
False ceiling installation
Instalación en el cielo falso

fig. 2.1

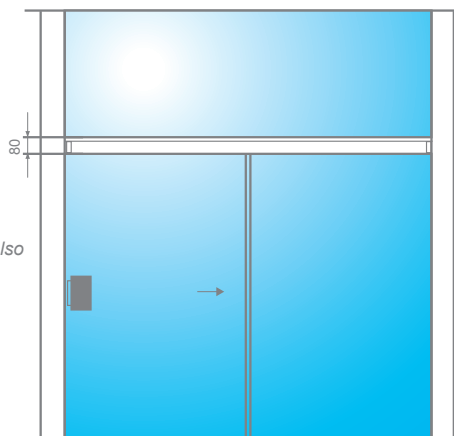
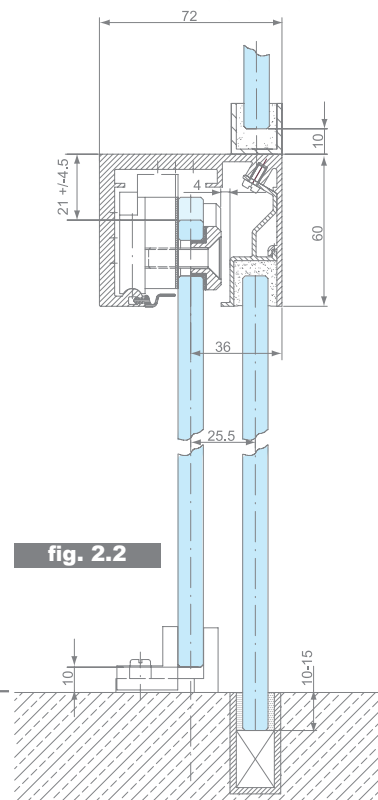

fig. 2.2



Art. 4-020
Guarnizione a spazzolino
Brush seal - Perfil cepillo

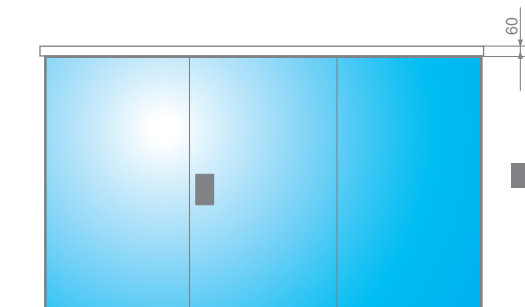
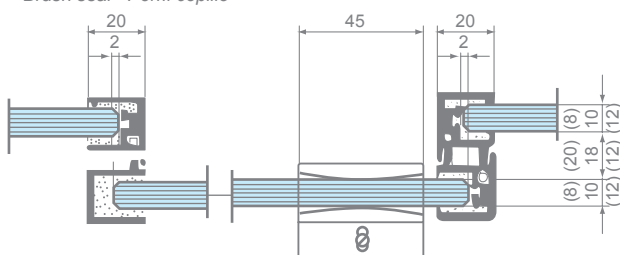
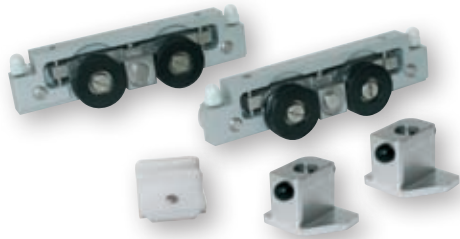

fig. 3



Art. No. 4-501

Set di accessori per anta scorrevole max. 150 kg (per spessori vetro 8-10-12 mm) composto da:

- 2 morsetti 160 mm/cad.
- 2 stoppers (art. no. 4-517)
- 1 blocchetto guida a pavimento (art. no. 4-009).

Set for sliding panel max. 150 kg (for 8-10-12 mm glass thicknesses) composed by:

- 2 clamps 160 mm/each
- 2 stoppers (art. no. 4-517)
- 1 floor guiding patch (art. no. 4-009).

Set de accesorios para una hoja corredera max. 150 kg (para espesores de 8-10-12 mm) compuesto de:

- 2 abrazaderas de 160 mm/cada una
- 2 stoppers (art. no. 4-517)
- 1 accesorio guía a pavimento (art. no. 4-009).



Art. No. 4-502 / 4-503

Guida di scorrimento preparata per il fissaggio al soffitto (4-502) o alla parete (4-503) - lunghezze:

Runner rail prepared for ceiling (4-502) or wall (4-503) fastening - lengths:

Guía de deslizamiento preparada para fijar al techo (4-502) ó a la pared (4-503) - largos:

Finiture in alluminio disponibili

Available aluminium finishes - Acabados en aluminio disponibles

- **610 Grezzo** - Not anodized - Sin anodizar
- **611 Anodizzato naturale** - Silver anodized - Anodizado natural
- **680 Simile acciaio inox** - Similar to stainless steel - Parecido acero inox
- **615 Anodizzato bronzo scuro** - Dark bronze anodized - Anodizado bronzo oscuro
- **RAL9016 Laccato bianco** - White powder coated - Lacado blanco

Art. No. 4-512

Guida con fisso preparata per il fissaggio a soffitto

Runner rail with fix panel prepared for ceiling fastening - lengths:

Guía de deslizamiento con fijo completa preparada para fijar al techo - largos:

1500 mm
2000 mm
2500 mm
3000 mm
3500 mm
4000 mm
4500 mm
6000 mm

1500 mm
2000 mm
2500 mm
3000 mm
3500 mm
4000 mm
4500 mm
6000 mm

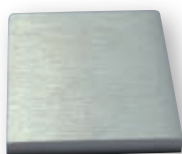

Art. No. 4-504

Tappo laterale per guida 4-502 e 4-503
End cap for runner rails 4-502 and 4-503
Tapón de cierre de la guía 4-502 y 4-503

Art 4-514 / 4-515

Tappo laterale (sinistro e destro) per guida 4-512
End cap (left and right) for runner rail 4-512
Tapón de cierre (izquierdo y derecho) de la guía 4-512



Art. No. 4-516

Spazzolino in silicone
Silicone brush
Cepillo de silicona



Art. No. 4-015

Profilo di chiusura della guida per il fisso laterale
Profile for side fixed panel guide closing
Perfil para cerrar lo espacio de la guía de la hojas fijas de vidrio

2000 mm
2300 mm
2500 mm
2700 mm
2900 mm
6000 mm



Art. No. 4-009

Blocchetto guida a pavimento in polyamide completo di viti e tasselli (adattabile allo spessore del vetro).

Floor guiding patch in polyamide complete with fastening set (self adjustable to glass thickness).

Accesorio guía a pavimento en polyamida completo de tornillos y tacos adaptable al espesor del vidrio.

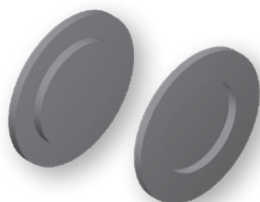

Art. No. 4-121

Maniglie a conchiglia per anta scorrevole diametro 70 richiedono un foro nel vetro da 50mm.

Shell type handle for sliding wing Ø 70mm, borehole in glass of 50mm.

Manecillas a concha para puerta corredera de 70mm de diámetro, que necesitan una muesca en el vidrio de 50mm.

componenti

components - componentes

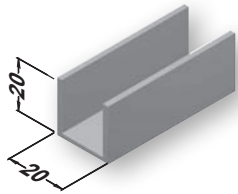

Art. No. 10-001

Guida a U 20/20/2 in barre da 6m senza fori
U-channel 20/20/2 in 6m bars without holes
Guía a U 20/20/2 en tramos de 6m sin agujeros

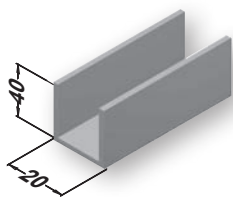

Art. No. 10-005

Guida a U 40/20/2,5 in barre da 6m senza fori
U-channel 40/20/2,5 in 6m bars without holes
Guía a U 40/20/2,5 en tramos de 6m sin agujeros

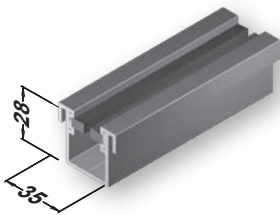

Art. No. 4-271

(Art. No. 4-275x8mm - 4-276x10mm - 4-277x12mm da richiedere a parte)
Guida a pavimento predisposta per guarnizione a spazzolino.

(Art. No. 4-275x8mm - 4-276x10mm - 4-277x12mm on request)
Floor guide channel prepared for brushes on both sides.

(Art. No. 4-275x8mm - 4-276x10mm - 4-277x12mm sobre pedido)
Guía para pavimento preparada para perfil de cepillo en ambos lados.

Usare spazzolino - Use brush - Utilizar cepillo:

Art. No. 4-275

per vetro da 8mm - for 8mm glass - para vidrio desde 8mm

Art. No. 4-276

per vetro da 10mm - for 10mm glass - para vidrio desde 10mm

Art. No. 4-277

per vetro da 12mm - for 12mm glass - para vidrio desde 12mm

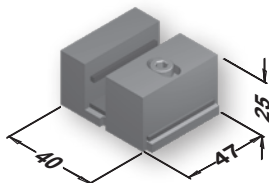

Art. No. 4-235

Guida a pavimento in acciaio inossidabile regolabile per vetro da 8-10-12mm completa di viti di fissaggio.

Bottom floor guide made of stainless steel adjustable to the various glass thicknesses (8-10-12mm), fixing screws included.

Guía para pavimento en acero inoxidable adaptable a espesores de cristal de 8-10-12mm, con tornillos de fijación incluidos.

Glass Wall

www.casma.com



Technology



CASMA si riserva il diritto di modificare i propri prodotti
senza preavviso.
CASMA reserves the right to make modifications without notice.
CASMA se reserva el derecho
de hacer modificaciones sin previo aviso.



CASMA S.p.A.

Via Primo Maggio, 86 - 20013 **MAGENTA** (MI) - Italy
ph. +39 02 97298418 - fax +39 02 97299006
www.casma.com - casma@casma.it