

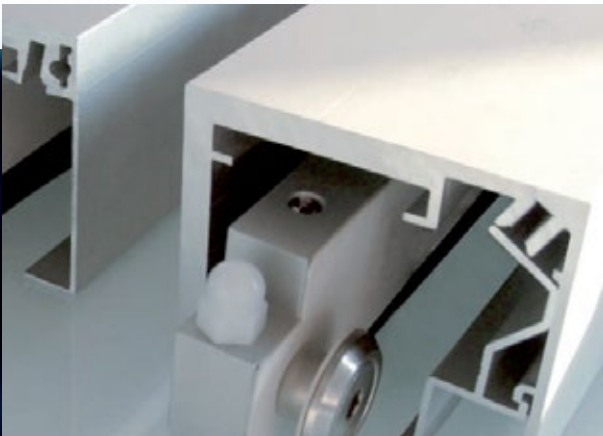

ELITE GLASS  
SOLUTIONS



*PICO*



# Glass Wall



HEAD OFFICE 114 Endeavour Way, Sunshine West VIC 3020 Australia

ADELAIDE OFFICE 7 Manfull Street, Melrose Park SA 5039 Australia

☎ 1300 4 ELITE | 03 9314 6105

✉ [sales@eliteglassolutions.com.au](mailto:sales@eliteglassolutions.com.au) | [www.eliteglassolutions.com.au](http://www.eliteglassolutions.com.au)

by CASMA  
**Pico**

# Technology

PICO is a further evolution in the glass sliding system product range.  
The upper track of PICO is available in two different versions  
with and without side fixed panel.  
The set of clamps and stoppers are very small  
and totally hidden in the upper track.  
Pico is an ideal solution for false ceiling installation.  
In fact the glass panel can be easily hung and adjusted  
from below the false ceiling level.  
Glass panel weight should not exceed 150Kg and 12mm thickness.  
Glass cut outs are required to assure maximum security.



Vetrografica Vallati - ROMA



Vetreria Riccionese - RI

**HEAD OFFICE** 114 Endeavour Way, Sunshine West VIC 3020 Australia  
**ADELAIDE OFFICE** 7 Manfull Street, Melrose Park SA 5039 Australia

☎ 1300 4 ELITE | 03 9314 6105

✉ [sales@eliteglasssolutions.com.au](mailto:sales@eliteglasssolutions.com.au) | 🌐 [www.eliteglasssolutions.com.au](http://www.eliteglasssolutions.com.au)

## Installation types

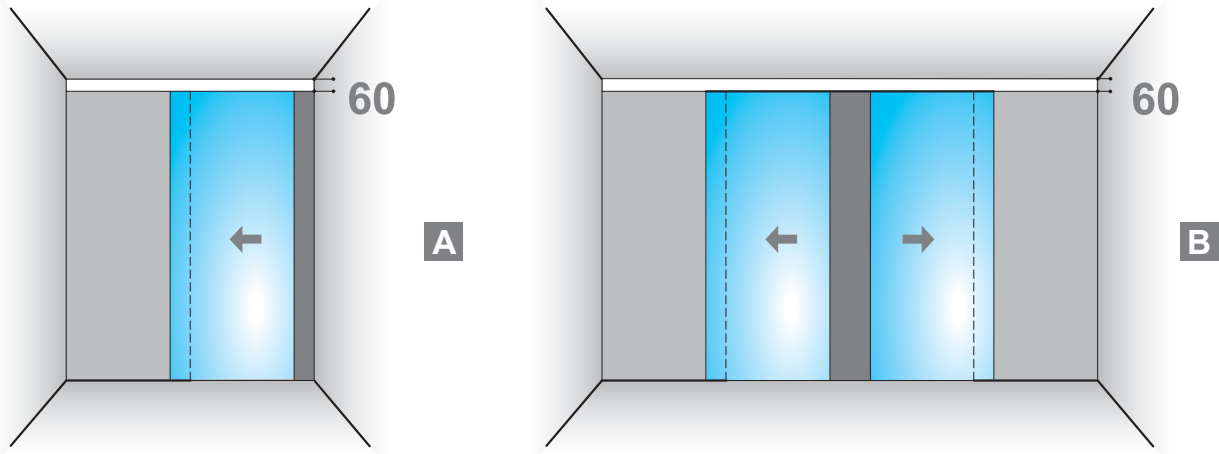

The upper runner rail has 2 fastening possibilities: one opposite to wall (fig.1.1) and one to ceiling (fig.1.2).

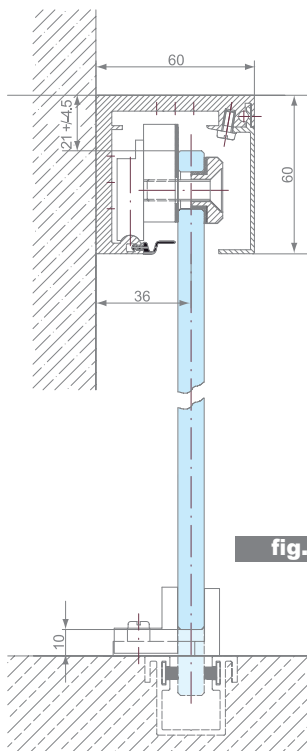

fig. 1.1

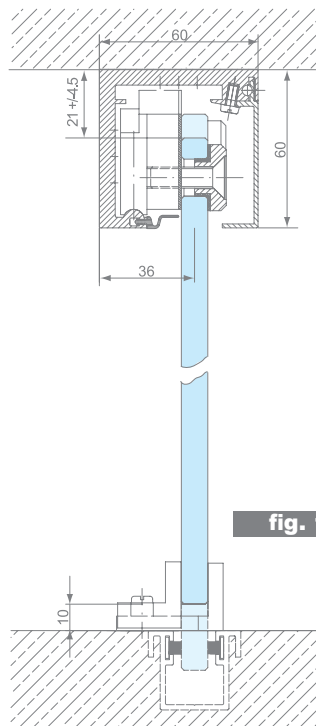
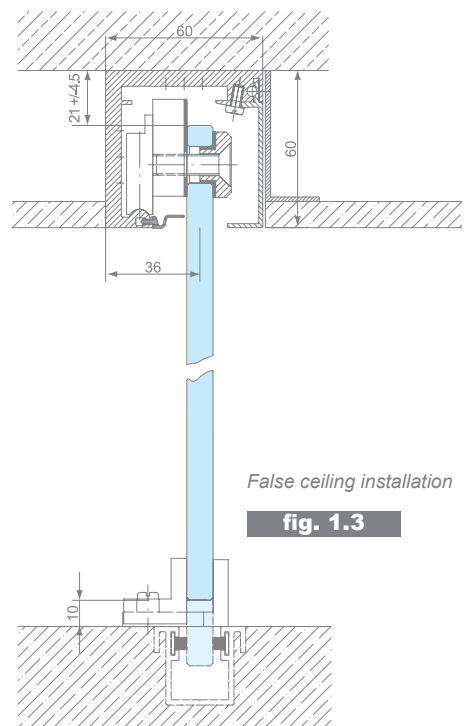

fig. 1.2



False ceiling installation

fig. 1.3

**HEAD OFFICE** 114 Endeavour Way, Sunshine West VIC 3020 Australia

**ADELAIDE OFFICE** 7 Manfull Street, Melrose Park SA 5039 Australia

☎ 1300 4 ELITE | 03 9314 6105

✉ sales@eliteglassolutions.com.au | 🌐 www.eliteglassolutions.com.au

# technical section

## Art. 4-507

Connection plate (fig. 1.4) for fixing the runner rail to the overpanel.

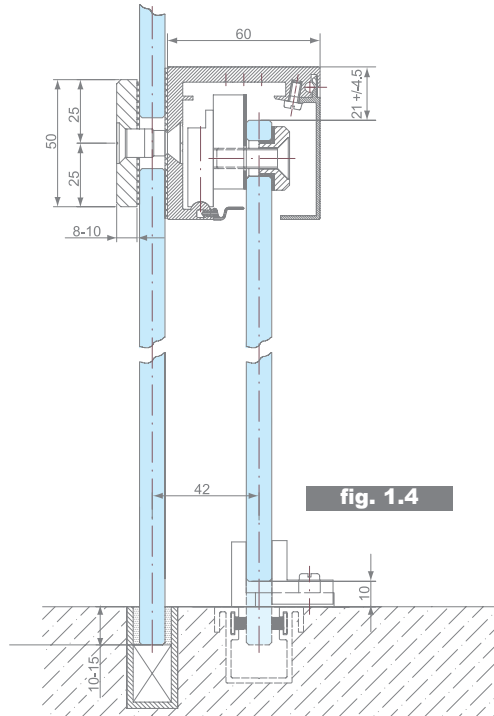
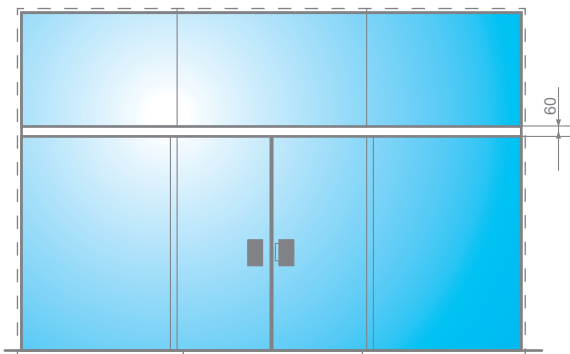

## Glass cut out

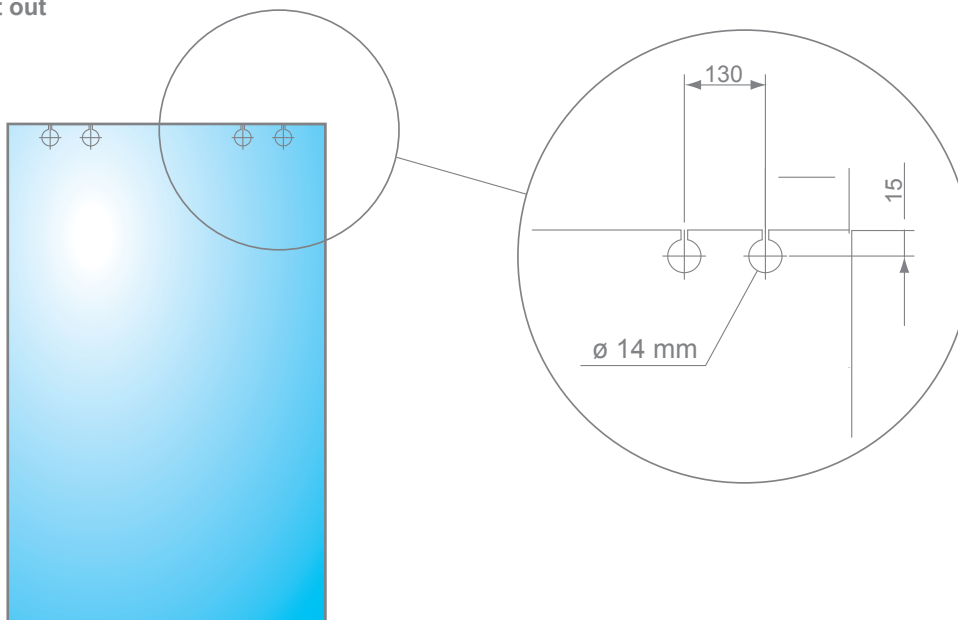

**HEAD OFFICE** 114 Endeavour Way, Sunshine West VIC 3020 Australia

**ADELAIDE OFFICE** 7 Manfull Street, Melrose Park SA 5039 Australia

☎ 1300 4 ELITE | 03 9314 6105

✉ sales@eliteglassolutions.com.au | 🌐 www.eliteglassolutions.com.au

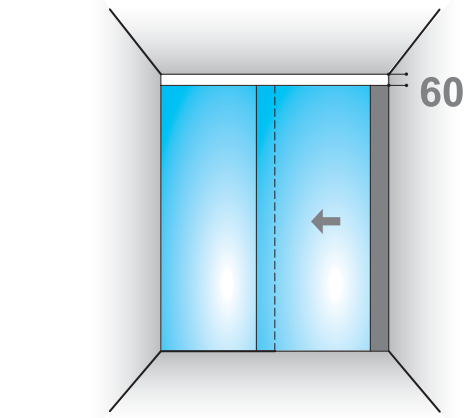

**C**

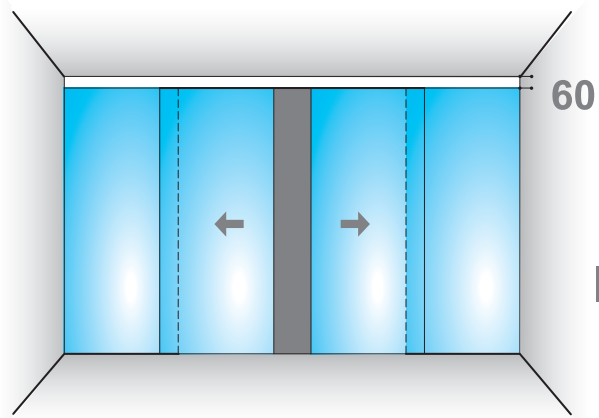

**D**

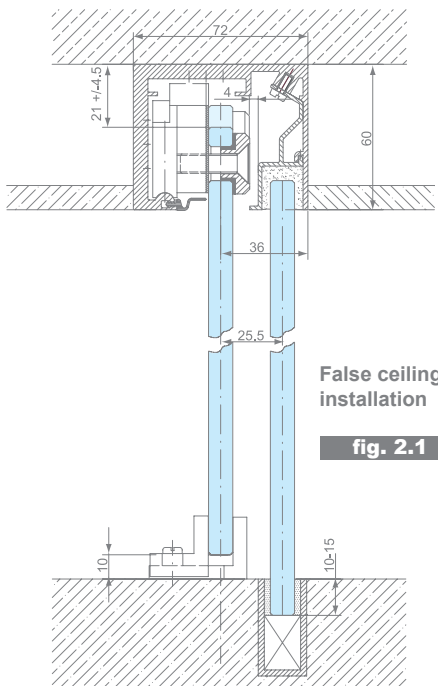

False ceiling installation  
**fig. 2.1**

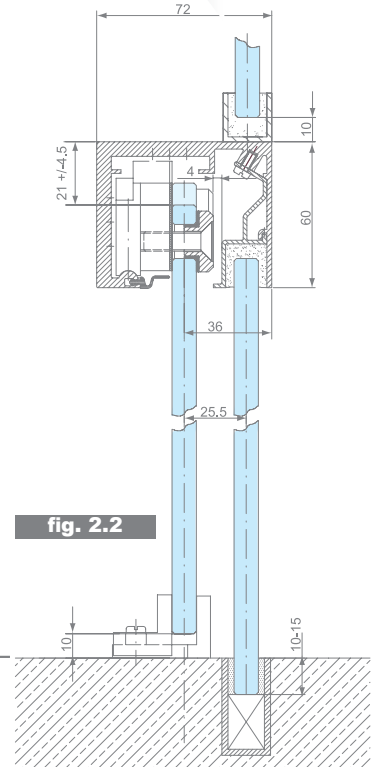
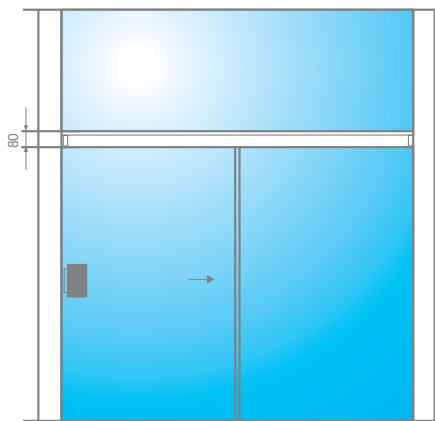

**fig. 2.2**

Art. 4-020  
Brush seal

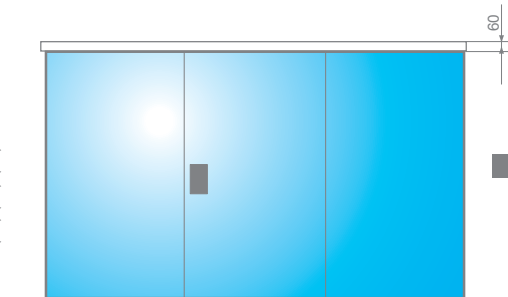
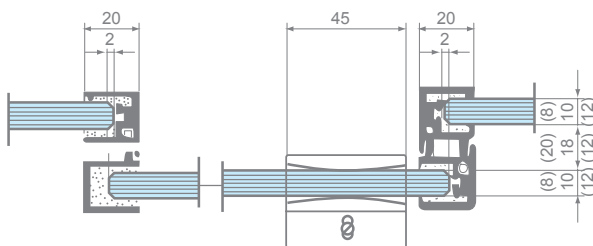

**fig. 3**

**HEAD OFFICE** 114 Endeavour Way, Sunshine West VIC 3020 Australia  
**ADELAIDE OFFICE** 7 Manfull Street, Melrose Park SA 5039 Australia

☎ 1300 4 ELITE | 03 9314 6105

✉ sales@eliteglassolutions.com.au | 🌐 www.eliteglassolutions.com.au

# components



## Art. No. 4-501

Set for sliding panel max. 150 kg (for 8-10-12 mm glass thicknesses) composed by:

- 2 clamps 160 mm/each
- 2 stoppers (art. no. 4-519)
- 1 floor guiding patch (art. no. 4-009).



## Art. No. 4-511

Set for sliding panel max. 75 kg (for 8-10 mm glass thicknesses) composed by:

- 2 clamps 115 mm/each
- 2 stoppers (art. no. 4-519)
- 1 floor guiding patch (art. no. 4-009).



## Art. No. 4-521 (solo con – only with 4-502 / 4-503)

Set for sliding panel max. 50 kg (for 8-10 mm glass thicknesses) composed by:

- 2 clamps 60 mm/each
- 2 stoppers (art. no. 4-519)
- 1 floor guiding patch (art. no. 4-009).



## Art. No. 4-502 / 4-503

Runner rail prepared for ceiling (4-502) or wall (4-503) fastening - lengths:

Available aluminium finishes

- 610 Not anodized
- 611 Silver anodized
- 680 Similar to stainless steel
- 615 Dark bronze anodized
- RAL9016 White powder coated

1500 mm  
2000 mm  
2500 mm  
3000 mm  
3500 mm  
4000 mm  
4500 mm  
6000 mm

## Art. No. 4-512

Runner rail with fix panel prepared for ceiling fastening - lengths:

1500 mm  
2000 mm  
2500 mm  
3000 mm  
3500 mm  
4000 mm  
4500 mm  
6000 mm

**HEAD OFFICE** 114 Endeavour Way, Sunshine West VIC 3020 Australia

**ADELAIDE OFFICE** 7 Manfull Street, Melrose Park SA 5039 Australia

☎ 1300 4 ELITE | 03 9314 6105

✉ sales@eliteglassolutions.com.au | 🌐 www.eliteglassolutions.com.au



**Art. No. 4-504**

End cap for runner rails 4-502 and 4-503

**Art 4-514 / 4-515**

End cap (left and right) for runner rail 4-512



**Art. No. 4-516**

Silicone brush



**Art. No. 4-015**

Profile for side fixed panel guide closing

2000 mm  
2300 mm  
2500 mm  
2700 mm  
2900 mm  
6000 mm

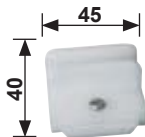

**Art. No. 4-009**

Floor guiding patch in polyamide complete with fastening set (self adjustable to glass thickness).

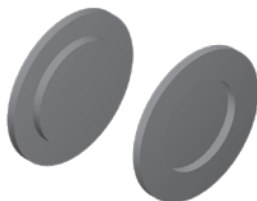

**Art. No. 4-121**

Shell type handle for sliding wing Ø 70mm, borehole in glass of 50mm.

**HEAD OFFICE** 114 Endeavour Way, Sunshine West VIC 3020 Australia

**ADELAIDE OFFICE** 7 Manfull Street, Melrose Park SA 5039 Australia

☎ 1300 4 ELITE | 03 9314 6105

✉ sales@eliteglassolutions.com.au | 🌐 www.eliteglassolutions.com.au



# components

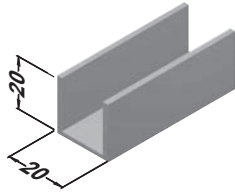

**Art. No. 10-001**

U-channel 20/20/2 in 6m bars without holes

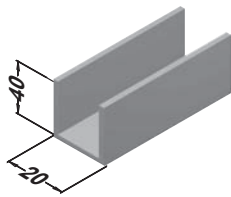

**Art. No. 10-005**

U-channel 40/20/2,5 in 6m bars without holes

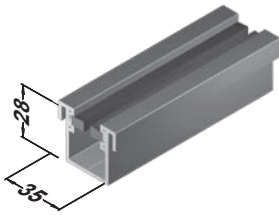

**Art. No. 4-271**

(Art. No. 4-275x8mm - 4-276x10mm - 4-277x12mm on request)  
Floor guide channel prepared for brushes on both sides.

Use brush

**Art. No. 4-275**  
for 8mm glass

**Art. No. 4-276**  
for 10mm glass

**Art. No. 4-277**  
for 12mm glass

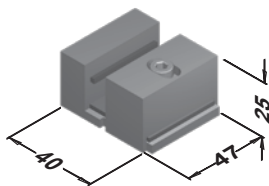

**Art. No. 4-235**

Bottom floor guide made of stainless steel adjustable to the various glass thicknesses (8-10-12mm), fixing screws included.

**HEAD OFFICE** 114 Endeavour Way, Sunshine West VIC 3020 Australia

**ADELAIDE OFFICE** 7 Manfull Street, Melrose Park SA 5039 Australia

☎ 1300 4 ELITE | 03 9314 6105

✉ sales@eliteglassolutions.com.au | 🌐 www.eliteglassolutions.com.au

by 

# Glass Wall

[www.casma.com](http://www.casma.com)



**HEAD OFFICE** 114 Endeavour Way, Sunshine West VIC 3020 Australia

**ADELAIDE OFFICE** 7 Manfull Street, Melrose Park SA 5039 Australia

 1300 4 ELITE | 03 9314 6105

 [sales@eliteglassolutions.com.au](mailto:sales@eliteglassolutions.com.au) |  [www.eliteglassolutions.com.au](http://www.eliteglassolutions.com.au)

by CASMA  
**Pico**

# Technology



CASMA reserves the right to make modifications without notice.



**HEAD OFFICE** 114 Endeavour Way, Sunshine West VIC 3020 Australia

**ADELAIDE OFFICE** 7 Manfull Street, Melrose Park SA 5039 Australia

☎ 1300 4 ELITE | 03 9314 6105

✉ [sales@eliteglassolutions.com.au](mailto:sales@eliteglassolutions.com.au) | 🌐 [www.eliteglassolutions.com.au](http://www.eliteglassolutions.com.au)



*speedy gedasa*



TECHNOLOGICAL PRODUCTS  
FOR GLASS ARCHITECTURE

SPEEDYBYCASMA Srl



ELITE GLASS  
SOLUTIONS

**HEAD OFFICE** 114 Endeavour Way, Sunshine West VIC 3020 Australia

**ADELAIDE OFFICE** 7 Manfull Street, Melrose Park SA 5039 Australia

 1300 4 ELITE | 03 9314 6105

 [sales@eliteglassolutions.com.au](mailto:sales@eliteglassolutions.com.au) |  [www.eliteglassolutions.com.au](http://www.eliteglassolutions.com.au)